

## On-Vehicle Inspection

### CHECK DRIVE BELT TENSION

Using a belt tension gauge, check the drive belt tension.

**Belt tension gauge:**

**Nippondenso BTG-20 (95506-00020) or**

**Borroughs No.BT-33-73F**

**Drive belt tension:**

**New belt  $160 \pm 20$  lb**

**Used belt  $100 \pm 20$  lb**

**HINT:**

- "New belt" refers to a belt which has been less than 5 minutes on a running engine.
- "Used belt" refers to a belt which has been used on a running engine for 5 minutes or more.
- After installing the drive belt, check that it fits properly in the ribbed grooves.

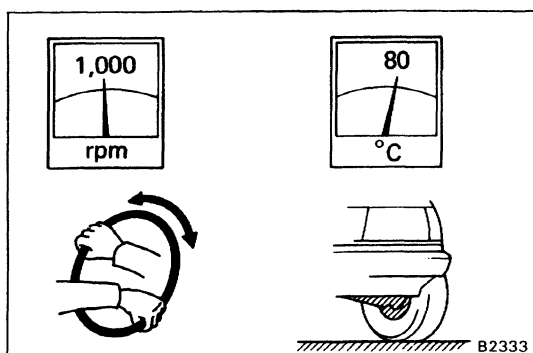
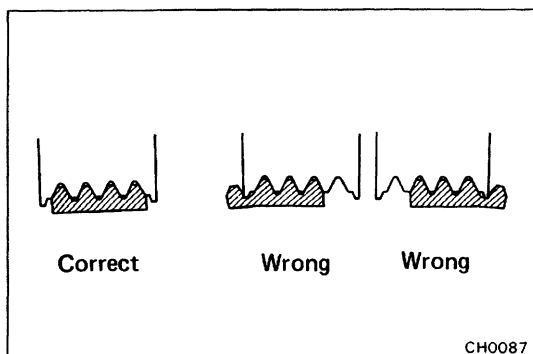
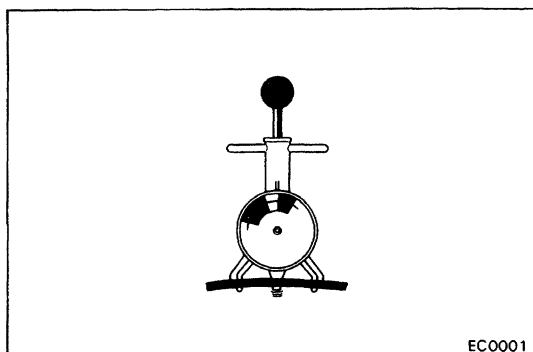

## FLUID LEVEL CHECK

### 1. KEEP VEHICLE LEVEL

### 2. BOOST FLUID TEMPERATURE

With the engine idling at 1,000 rpm or less, turn the steering wheel from lock to lock several times to boost fluid temperature. ,

**Fluid temperature:  $80^{\circ}\text{C}$  ( $176^{\circ}\text{F}$ )**

### 3. CHECK FOR FOAMING OR EMULSIFICATION

**HINT:** Foaming and emulsification indicate either the existence of air in the system or that the fluid level is too low.

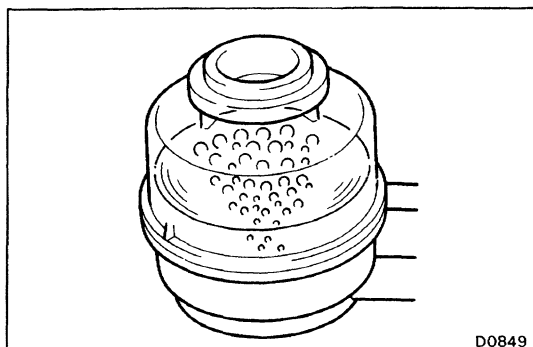

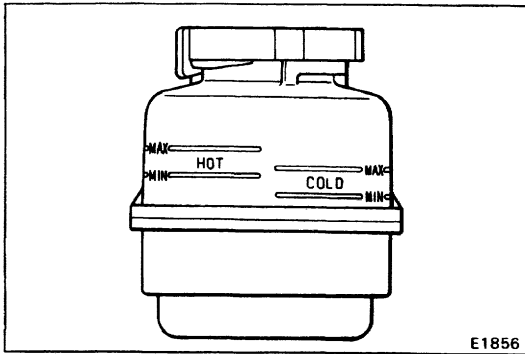

#### 4. CHECK FLUID LEVEL IN RESERVOIR

Check the fluid level and add fluid if necessary.

**Fluid: ATF DEXRON® II**

HINT: Check that the fluid level is within the HOT RANGE of the tank. If the fluid is cold, check that it is within the COLD RANGE of the tank.

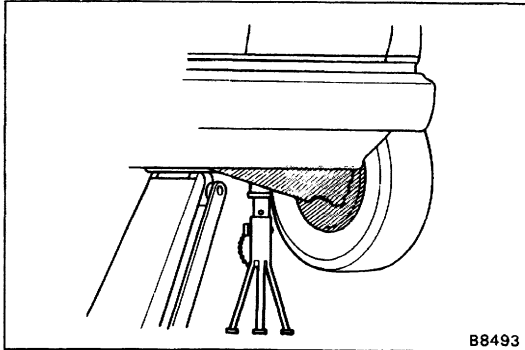

## REPLACEMENT OF POWER STEERING FLUID

1. JACK UP FRONT OF VEHICLE AND SUPPORT IT WITH STANDS

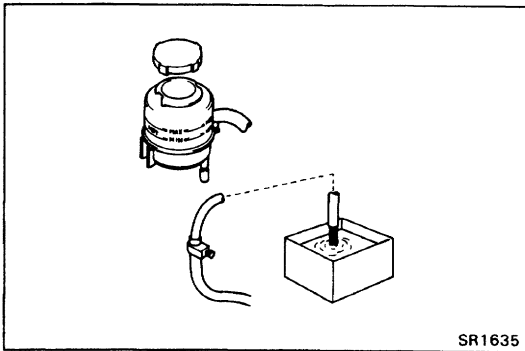

2. REMOVE FLUID RETURN HOSE FROM RESERVOIR TANK AND DRAIN FLUID INTO CONTAINER

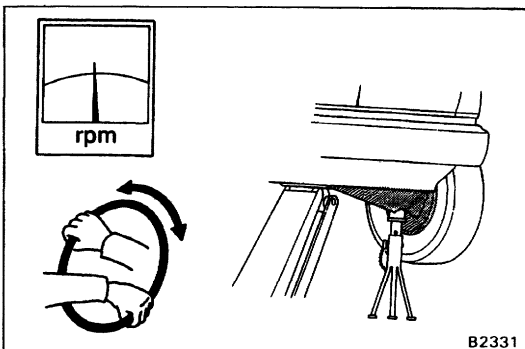

3. WITH ENGINE IDLING, TURN STEERING WHEEL FROM LOCK TO LOCK WHILE DRAINING FLUID
4. STOP ENGINE

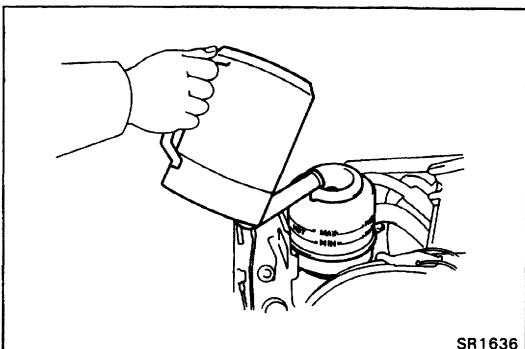

5. FILL RESERVOIR TANK WITH FRESH FLUID  
**Fluid: ATF DEXRON® II**

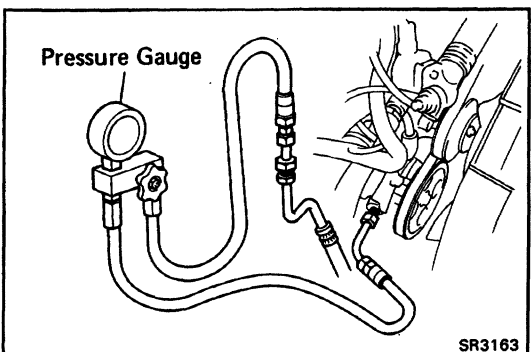
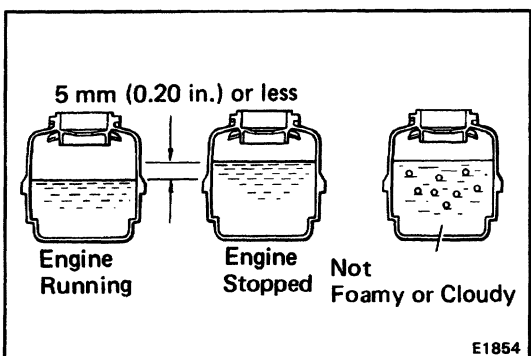
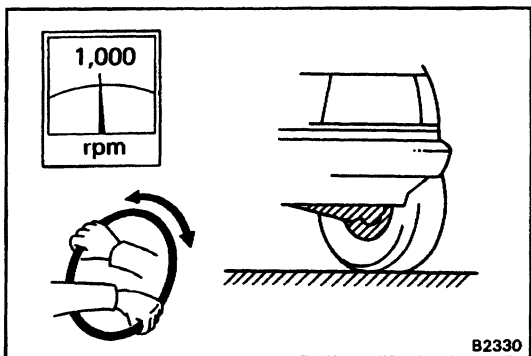
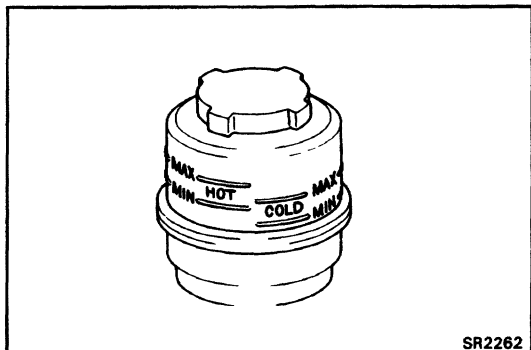
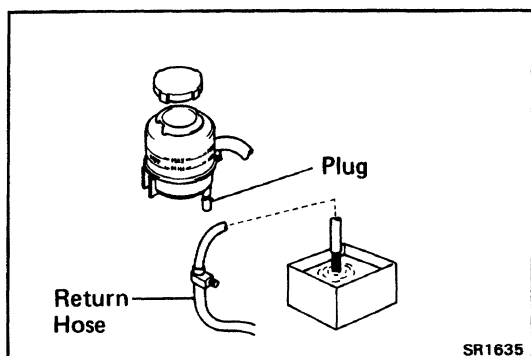

## 6. START ENGINE AND RUN 1T AT 1,000 RPM

After 1 or 2 seconds, fluid will begin to discharge from the return hose. Stop the engine immediately at this time.

**NOTICE:** Take care that some fluid remains left in the reservoir tank.

## 7. REPEAT STEPS 5 AND 6 FOUR OR FIVE TIMES UNTIL THERE IS NO MORE AIR IN FLUID

## 8. CONNECT RETURN HOSE TO RESERVOIR TANK

## 9. BLEED POWER STEERING SYSTEM

# BLEEDING OF POWER STEERING SYSTEM

### 1. CHECK FLUID LEVEL IN RESERVOIR TANK

Check the fluid level and add fluid if necessary.

**Fluid: ATF DEXRON® II**

**HINT:** Check that the fluid level is within the **HOT RANGE** of the tank. If the fluid is cold, check that it is within the **COLD RANGE** of the tank.

### 2. START ENGINE AND TURN STEERING WHEEL FROM LOCK TO LOCK THREE OR FOUR TIMES

With the engine speed below 1,000 rpm, turn the steering wheel to left or right full lock and keep it there for 2 – 3 seconds, then turn the wheel to the reverse full lock and keep it there for 2 – 3 seconds.

### 3. CHECK THAT FLUID IN RESERVOIR IS NOT FOAMY OR CLOUDY AND DOES NOT RISE OVER MAXIMUM WHEN ENGINE IS STOPPED

Measure the fluid level with the engine running. Stop the engine and measure the fluid level.

**Maximum rise: 5 mm (0.20 in.)**

If a problem is found, repeat steps 7 and 8 on this page. Repair the PS if the problem persists.

## OIL PRESSURE CHECK

### 1. CONNECT PRESSURE GAUGE

- Disconnect the pressure line from the PS pump.  
SST 09631-22020
- Connect the gauge side of the pressure gauge to the PS pump and the valve side to the pressure line.
- Bleed the system. Start the engine and turn the steering wheel from lock to lock two or three times.
- Check that the fluid level is correct.

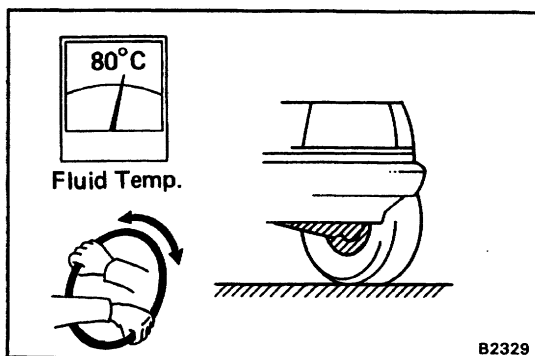

2. CHECK THAT FLUID TEMPERATURE IS AT LEAST 60 ° F (176 ° C)
3. START ENGINE AND RUN IT AT IDLE

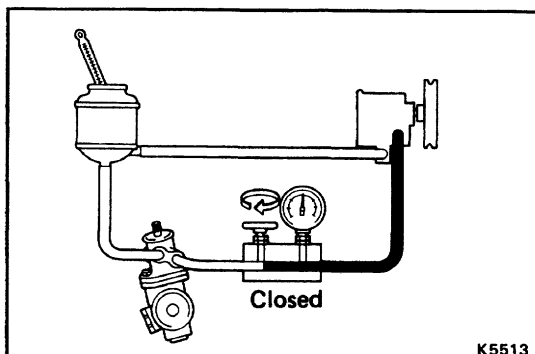

#### 4. CHECK FLUID PRESSURE READING WITH VALVE CLOSED

Close the pressure gauge valve and observe the reading on the gauge.

**Minimum pressure: 75 kg/cm<sup>2</sup> (1,067 psi, 7,355 kPa)**

**NOTICE: Do not keep the valve closed for more than 10 seconds.**

If pressure is low, repair or replace the PS pump.

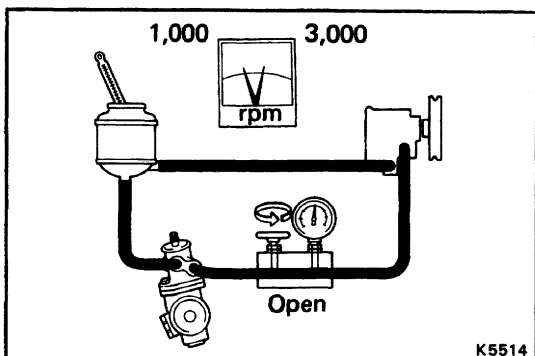

#### 5. OPEN VALVE FULLY

#### 6. CHECK AND RECORD PRESSURE READING AT 1,000 RPM

#### 7. CHECK AND RECORD PRESSURE READING AT 3,000 RPM

Check that there is 5 kg /cm<sup>2</sup> (71 psi, 490 kPa) or less difference in pressure between the 1,000 rpm and 3,000 rpm checks. If the difference is excessive, repair or replace the flow control valve of the PS pump.

#### 8. CHECK PRESSURE READING WITH STEERING WHEEL TURNED TO FULL LOCK

Be sure the pressure gauge valve is fully opened and the engine idling.

**Minimum pressure: 75 kg/cm<sup>2</sup> (1,067 psi, 7,355 kPa)**

**NOTICE: Do not maintain lock position for more than 10 seconds.**

If pressure is low, the gear housing has an internal leak or the solenoid is faulty.

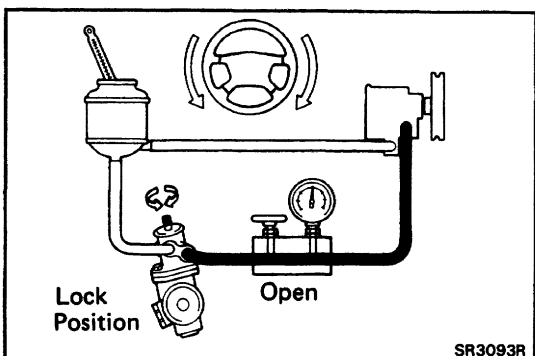

#### 9. MEASURE STEERING EFFORT

Center the steering wheel and run the engine at idle.

Using a torque meter, measure the steering effort in both directions.

**Maximum steering effort: 80 kg-cm (69 in.-lb, 7.8 N-m)**

If steering effort is excessive, repair the power steering unit.

**HINT: Be sure to consider the tire type, pressure and contact surface before making your diagnosis.**

