

BODY ELECTRICAL SYSTEM

GENERAL INFORMATION

Wiring color code

Wire colors are indicated by an alphabetical code.

- B = Black L = Blue R = Red
- BR = Brown LG = Light Green V = Violet
- G = Green O = Orange W = White
- GR = Gray P = Pink Y = Yellow

The first letter indicates the basic wire color and the second letter indicates the color of the stripe.

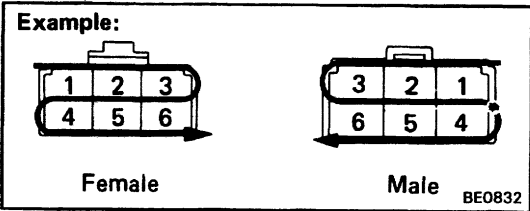
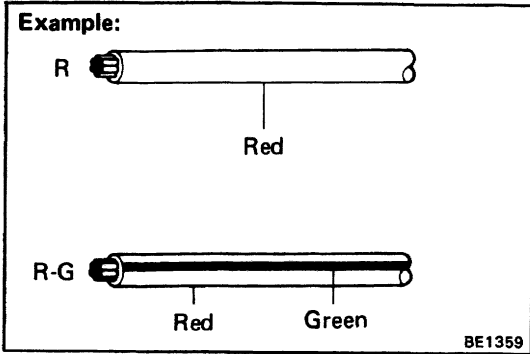

Connector

1. PIN NUMBER OF FEMALE CONNECTOR

Numbered in order from upper left to lower right.

2. PIN NUMBER OF MALE CONNECTOR

Numbered in order from upper right to lower left.

HINT: When connectors with different or the same number of terminals are used with the same parts, each connector name (letter of the alphabet) and pin number is specified.

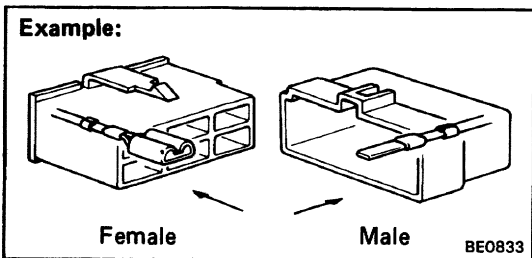
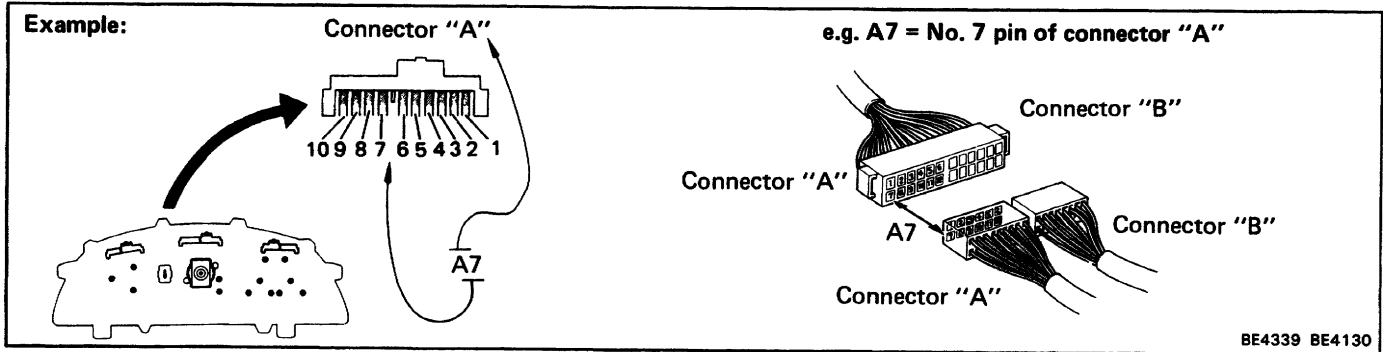

3. DISTINCTION OF MALE AND FEMALE CONNECTORS

Male and female connectors are distinguished by shape of their internal pins.

- (a) All connectors are shown from the open end, and the lock is on top.
- (b) To pull apart the connectors, pull on the connector itself, not the wires.

HINT: Check to see what kind of connector you are disconnecting before pulling apart.

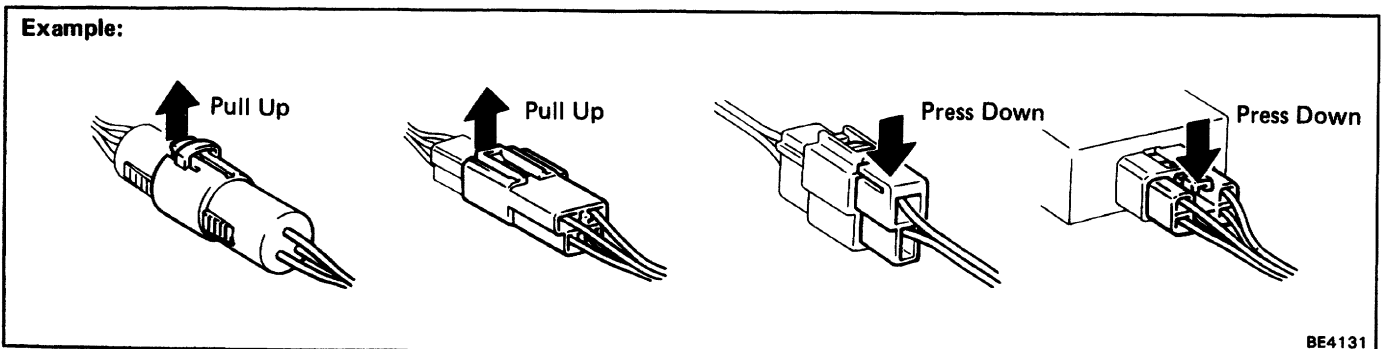

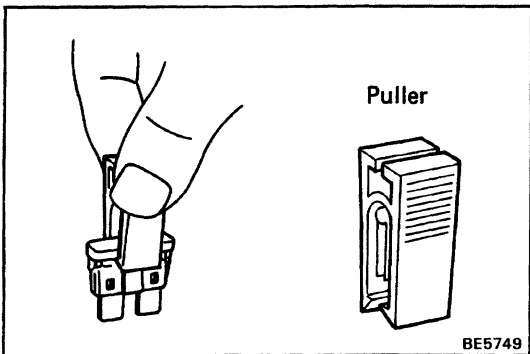
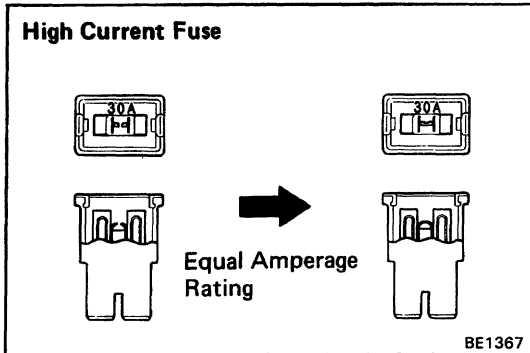
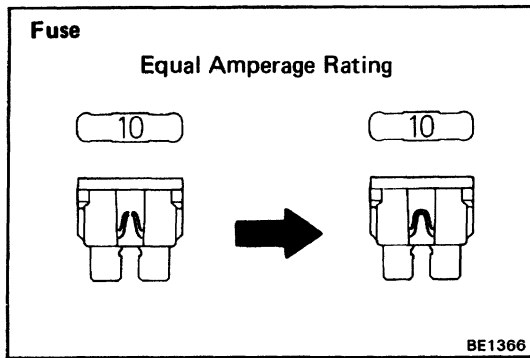

Replacement of High Current Fuse, Medium Current Fuse and Fuse

HINT: If replacing the fuse be sure to replace it with a fuse of fusible link with an equal amperage rating.

NOTICE:

1. Turn off all electrical components and the ignition switch before replacing a fuse or fusible link. Do not exceed the fuse or fusible link amperage rating.
2. Always use a fuse puller for removing and inserting a fuse. Remove and insert straight in and out without twisting. -Twisting could force open the terminals too much, resulting in a bad connection.

If a fuse or fusible link continues to blow, a short circuit is indicated. The system must be checked by a qualified technician.

How to Inspect for System Inspection

This inspection procedure is a simple troubleshooting which should be carried out on the vehicle during system operation and was prepared on the assumption of system component troubles (except for the wires and connectors, etc.).

Always inspect the trouble taking the following items into consideration.

- Ground point fault
- Open or short circuit of the wire harness
- Connector or terminal connection fault
- Fuse or fusible link fault

NOTICE:

1. This is an on-vehicle inspection during system operations. Therefore, inspect the trouble with due regard for security.
2. In case of connecting the battery directly, be careful not to short circuit, and select the applicable voltage.

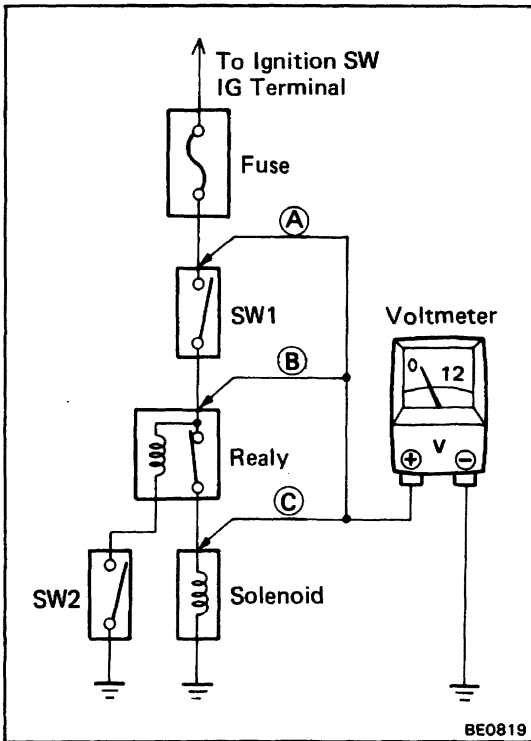

Check for Voltage

(a) Establish conditions in which voltage is present at the check point.

Example:

(A)– Ignition switch on

(B)– Ignition switch and switch 1 (SW 1) on.

(C)– Ignition switch, switch 1 (SW 1) and relay on (switch 2 (SW2) off).

(b) Using a voltmeter, connect the negative (-) lead to a good ground point or negative (-) battery terminal and the positive (+) lead to the connector or component terminal. This check can be done with a test bulb instead of a voltmeter.

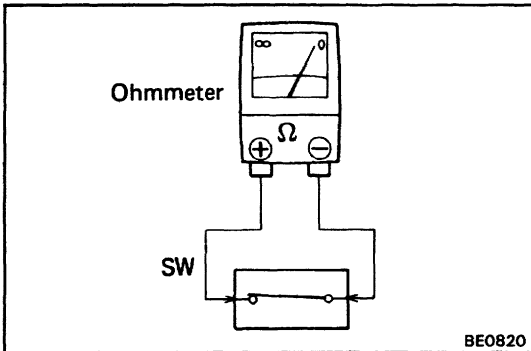

Check for Continuity and Resistance

(a) Disconnect the battery terminal or wire so there is no voltage between the check points.

(b) Contact the two leads of an ohmmeter to each of the check points.

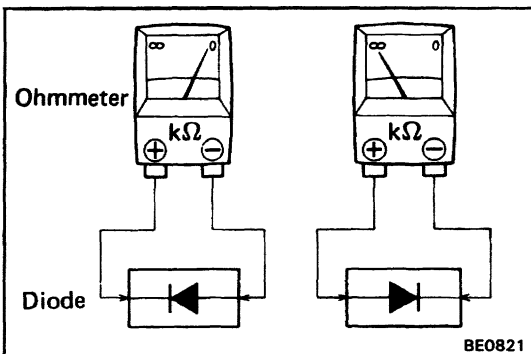

If the circuit has diodes, reverse the two leads and check again.

When contacting the negative (-) lead to the diode positive (+) side and the positive (+) lead to the negative (-) side, there should be continuity. When contacting the two leads in reverse, there should be no continuity. HINT: Specifications may vary depending on the type of tester, so refer to the tester's instruction manual before performing the inspection.

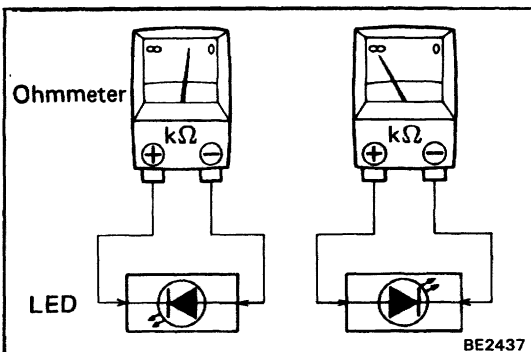

Check LED (Light Emitting Diode) in the same manner as that for diodes.

- Use a tester with a power source of 3 V or greater to overcome the circuit resistance.
- If a suitable tester is not available, apply battery voltage and check that the LED lights up.

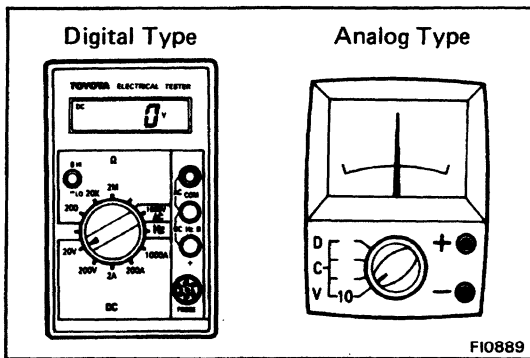

- (c) Use a volt/ohmmeter with high impedance (10 k/V minimum) for troubleshooting of the electrical circuit.

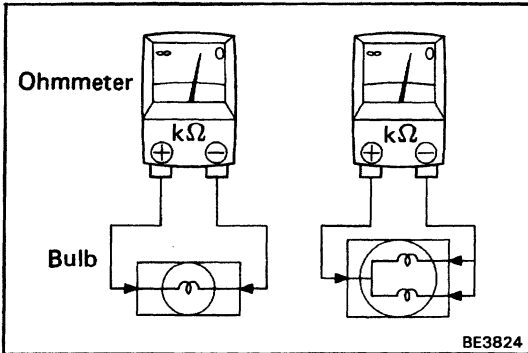

Check the Bulb

- Remove the bulb.
- There should be continuity between the respective terminals of the bulb together with a certain amount of resistance.
- Apply the two leads of the ohmmeter to each of the terminals.
- Apply battery voltage and check that the bulb light up.

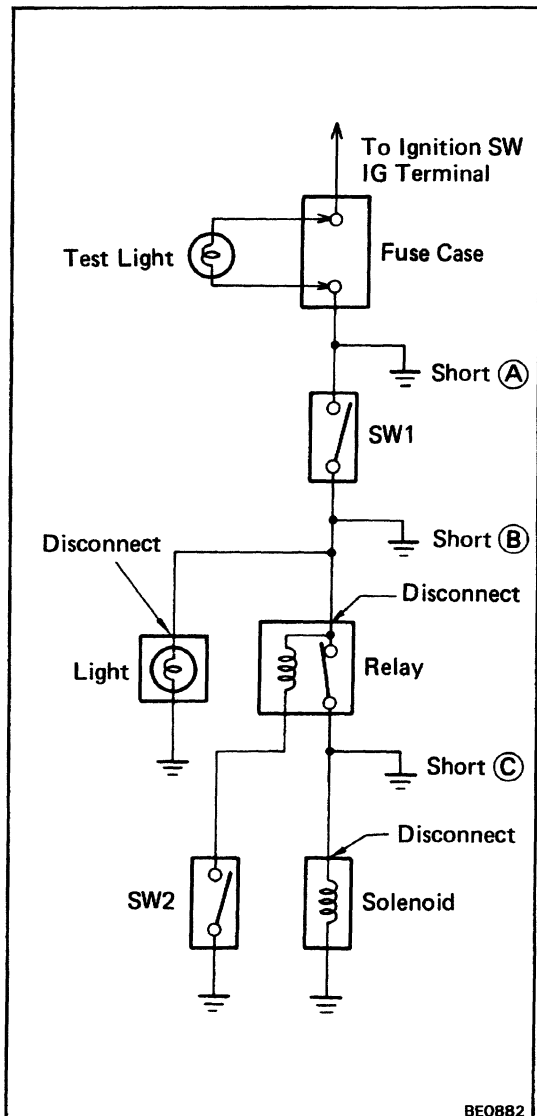

Check for Short Circuit

- Remove the blown fuse and eliminate all loads from the fuse.
- Connect a test bulb in place of the fuse.
- Establish conditions in which the test bulb comes on.

Example:

- Ignition switch on.
 - Ignition switch and switch 1 (SW 1) on.
 - Ignition switch, switch 1 (SW 1) and relay on (connect the relay) and switch 2 (SW2) off (or disconnect switch 2 (SW2)).
- (d) Disconnect and reconnect the connectors while watching the test bulb. The short lies between the connector where the test bulb stays lit and the connector where the bulb goes out.
- (e) Find the exact location of the short by lightly shaking the problem wire along the body.