

TROUBLESHOOTING WITH VOLT OHMMETER

HINT: The following troubleshooting procedures are designed for inspection of each separate system, and therefore the actual procedure may vary somewhat. However, troubleshooting should be performed referring to the inspection methods described in this manual.

Before beginning inspection, it is best to first make a simple check of the fuses, fusible links and condition of the connectors.

The following troubleshooting procedures are based on the supposition that the trouble lies in either a short or open circuit in a component outside the computer or a short circuit within the computer.

If engine trouble occurs even though proper operating voltage is detected in the computer connector, then it can be assumed that the engine ECU is faulty and should be replaced.

LOCATION OF FUSES AND FUSIBLE LINK

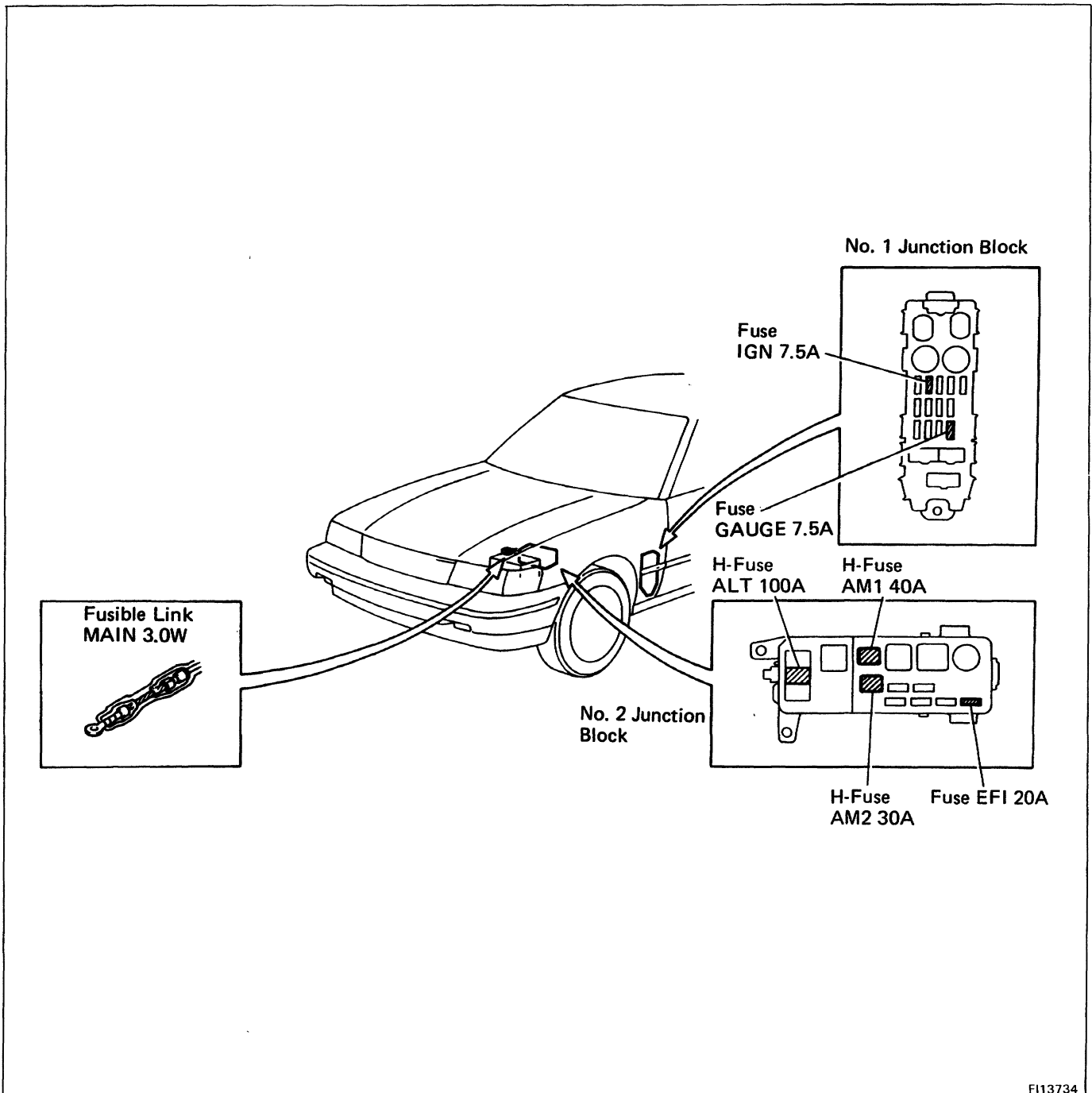

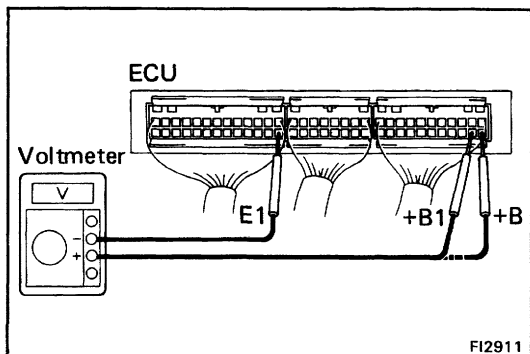
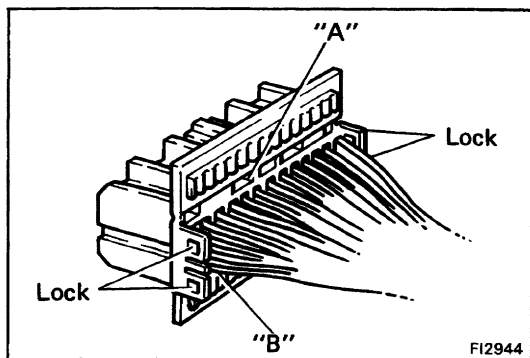

EFI SYSTEM CHECK PROCEDURE

PREPARATION

(a) Disconnect the connectors from the engine and ECT ECU.

(b) Remove the locks as shown in the illustration so that the tester probe(s) can easily come in.

NOTICE: Pay attention to sections "A" and "B" in the illustration which can be easily broken.

(c) Reconnect the connectors to the engine and ECT ECU.

HINT:

- Perform all voltage measurements with the connectors connected.
- Verify that the battery voltage is 11 V or more when the ignition switch is in the "ON" position.

Using a voltmeter with high impedance (10 kΩ/v minimum), measure the voltage at each terminal of the wiring connectors.

Terminals of Engine and ECT ECU

Symbol	Terminal Name	Symbol	Terminal Name	Symbol	Terminal Name
E01	POWER GROUND	G2	DISTRIBUTOR	A/C	A/C COMPRESSOR
E02	POWER GROUND	G1	DISTRIBUTOR	OD1	CRUISE CONTROL COMPUTER
No. 10	INJECTOR (No. 1 and 6)	NE	DISTRIBUTOR	SP1	NO. 1 SPEED SENSOR (Meter side)
No. 30	INJECTOR (No.4 and 5)	E1	COMPUTER GROUND	OD2	OD MAIN SWITCH
No. 20	INJECTOR (No.2 and 3)	VF	CHECK CONNECTOR	SP2	NO.2 SPEED SENSOR (A/T side)
STJ	COLD START INJECTOR	G(-)	DISTRIBUTOR	L1	TEMS ECU
EGR	VSV(EGR)	TE2	TDCL	TT	TDCL
-	-	TE1	CHECK CONNECTOR,TDCL	L2	TEMS ECU
-	-	ox1	OXYGEN SENSOR	FPR	FUEL PUMP RELAY
-	-	KNK	KNOCK SENSOR	L3	TEMS ECU
*HT	OXYGEN SENSOR HEATER	*ox2	SUB-OXYGEN SENSOR	W	WARNING LIGHT
A/D	CRUISE CONTROL COMPUTER	STP	STOP LIGHT SWITCH	L	SHIFT POSITION SWITCH
ISC1	ISC MOTOR NO. 1 COIL	THW	WATER TEMP. SENSOR	M-REL	EFI MAIN RELAY (COIL)
IGT	IGNITER	IDL	THROTTLE POSITION SENSOR	M	SHIFT POSITION SWITCH
ISC2	ISC MOTOR NO. 2 COIL	THA	AIR TEMP. SENSOR	P	SHIFT POSITION SWITCH
S1	ECT SOLENOID	VTA	THROTTLE POSITION SENSOR	S	SHIFT POSITION SWITCH
ISC 3	ISC MOTOR NO. 3 COIL	VS	AIR FLOW METER	IG SW	IGNITION SWITCH
S2	ECT SOLENOID	*THG	EGR GAS TEMP. SENSOR	+B	EFI MAIN RELAY
ISC4	ISC MOTOR NO. 4 COIL	VC	AIR FLOW METER, THROTTLE POSITION SENSOR	BATT	BATTERY
S3	ECT SOLENOID	E2	SENSOR GROUND	+B1	EFI MAIN RELAY
IGF	IGNITER	STA	STARTER SWITCH	-	-
ELS	HEAD LIGHT RELAY, DEFOGGER RELAY	NSW	NEUTRAL START SWITCH	-	-

Engine and ECT ECU Terminals

E01	No. 10	No. 20	EGR	-	*HT	ISC 1	ISC 2	ISC 3	ISC 4	IGF	G2	NE	VF	TE2	OX1	*OX2	THW	THA	VS	VC	STA	A/C	SP1	SP2	TT	FPR	W	M-REL	P	IG SW	BATT
E02	No. 30	STJ	-	-	A/D	IGT	S1	S2	S3	ELS	G1	E1	G(-)	TE1	KNK	STP	IDL	VTA	*THG	E2	NSW	OD1	OD2	L1	L2	L3	L	M	S	+B	+B1

* California specification vehicles only

Voltage at Engine and ECT ECU Wiring Connectors

No.	Terminals	Condition	STD Voltage	See page	
1	BATT - E1	-	10 - 14	FI-32	
	IG SW - E1	Ignition SW ON	10 - 14	FI-33	
	M-REL - E1			FI-34	
	+B (+B1) - E1				
2	IDL - E2	Ignition SW ON	Throttle valve open	4 - 6	FI-35
	VC - E2		-	4 - 6	FI-36
	VTA - E2		Throttle valve fully closed	0.1 - 1.0	
			Throttle valve fully open	3.2 - 4.2	
3	VC - E2	Ignition SW ON	-	4 - 6	FI-37
	VS - E2		Measuring plate fully closed	3.7 - 4.3	
			Measuring plate fully open	0.2 - 0.5	
			Idling	2.3 - 2.8	
	3,000 rpm		1.0 - 2.0		
4	No.10 E01	Ignition SW ON	10 - 14	FI-38	
	No.20 - E02				
	No.10				
5	THA - E2	Ignition SW ON	Intake air temperature 20°C (68°F)	1 - 3	FI-39
6	THW - E2	Ignition SW ON	Coolant temperature 80°C (176°F)	0.1 - 1.0	FI-40
7	STA - E1	Cranking		6 - 14	FI-41
8	IGT - E1	Idling		0.7 - 1.0	FI-42
9	ISC1 - E1	Ignition SW ON	9 - 14	FI-43	
	ISC4				
10	W - E1	No trouble ("CHECK" engine warning light off) and engine running		8 - 14	FI-44
11	A/C - E1	Ignition SW ON	Air conditioning ON	10 - 14	FI-45

Engine and ECT ECU Terminals

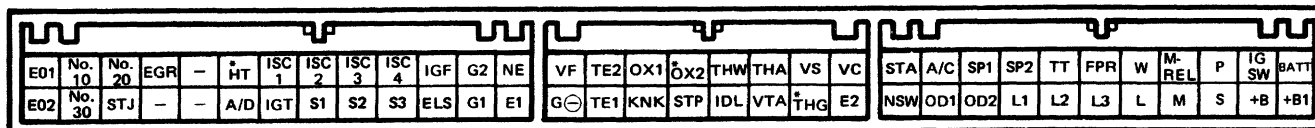

* California specification vehicles only

No.	Terminals	Trouble	Condition	STD Voltage
1	BATT - E1	No voltage	-	10 - 14 V
	IG SW - E1	No voltage	Ignition switch ON	10 - 14 V
	M-REL - E1	No voltage	Ignition switch ON	10 - 14 V
	+ B (+ B1) - E1	No voltage	Ignition switch ON	10 - 14 V

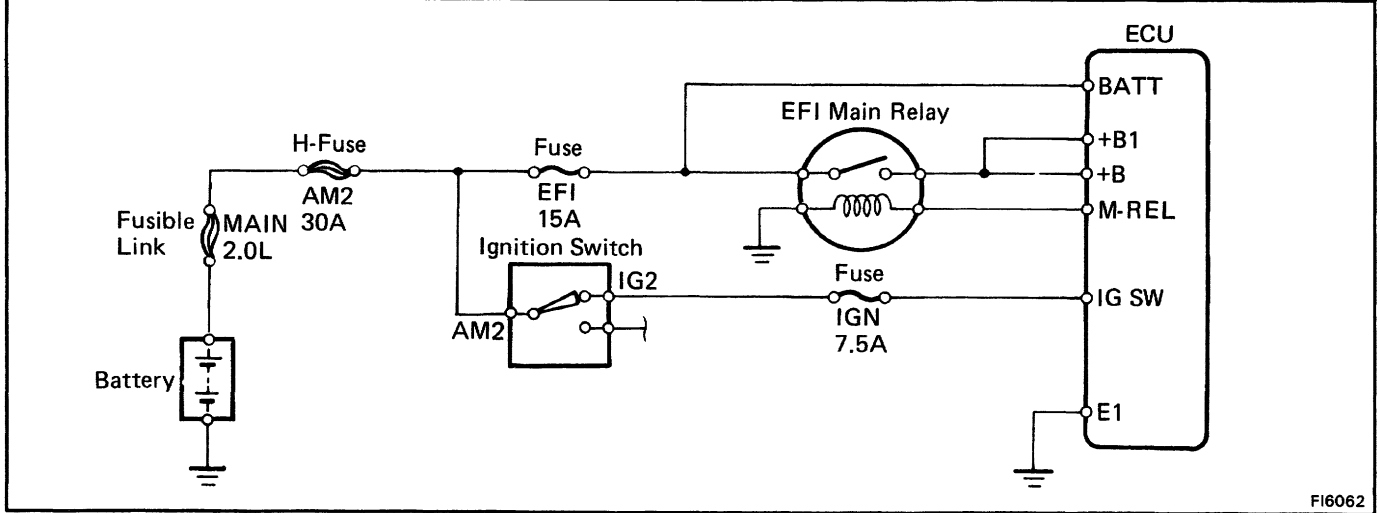

FI6062

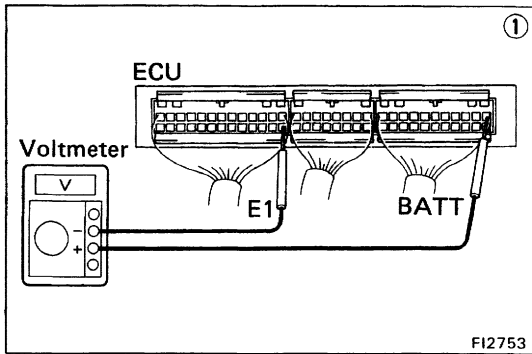

FI2753

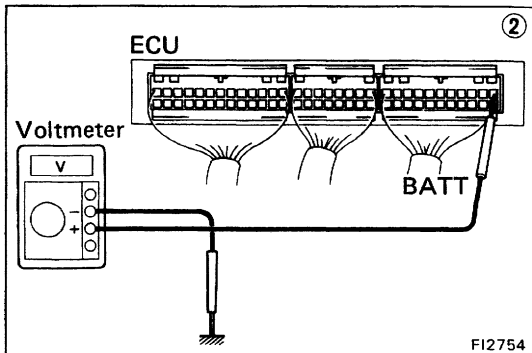

FI2754

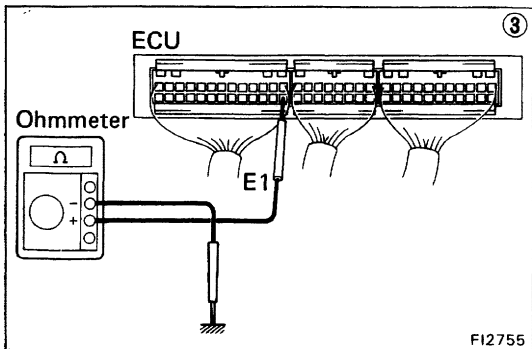

FI2755

• BATT - E1

```

    graph TD
      Step1["① There is no voltage between ECU terminals BATT and E1."] --> Step2["② Check that there is voltage between ECU terminal BATT and body ground."]
      Step2 -- NO --> Step4["Check fuse and fusible link."]
      Step2 -- OK --> Step3["③ Check wiring between ECU terminal E1. and body ground."]
      Step3 -- OK --> TryECU["Try another ECU."]
      Step3 -- BAD --> RepairECU["Repair or replace."]
      Step4 -- BAD --> ReplaceFuses["Replace."]
      Step4 -- OK --> Step5["Check wiring between ECU terminal and battery."]
      Step5 -- BAD --> RepairWiring["Repair or replace."]
      Step5 -- OK --> End[" "]
  
```

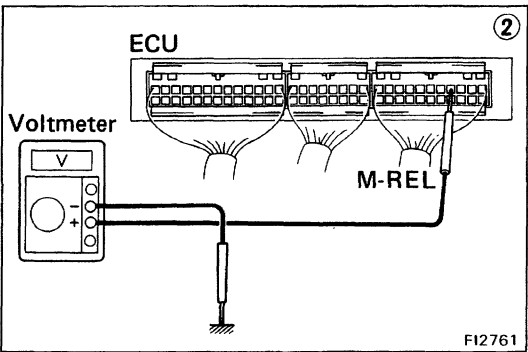
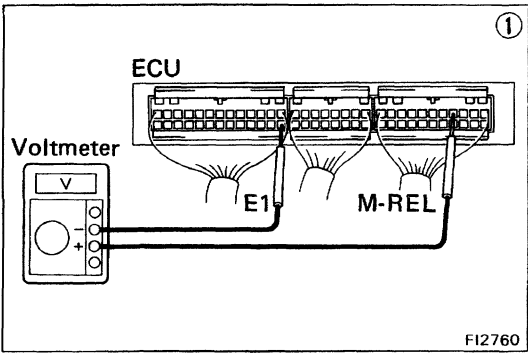
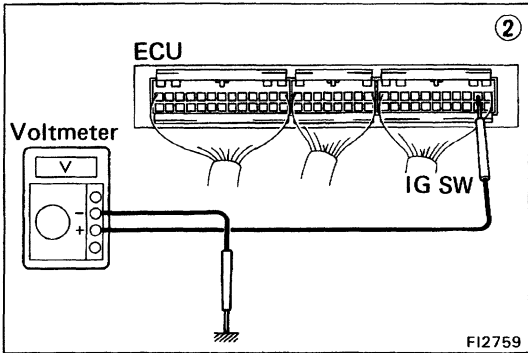
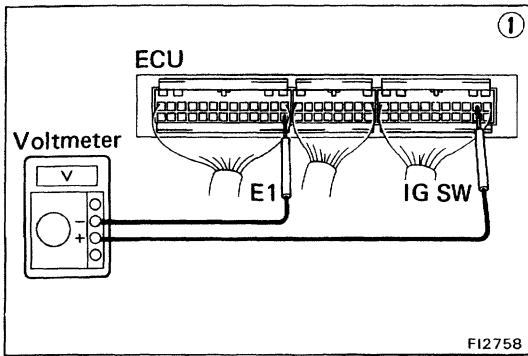

• IG SW - E1

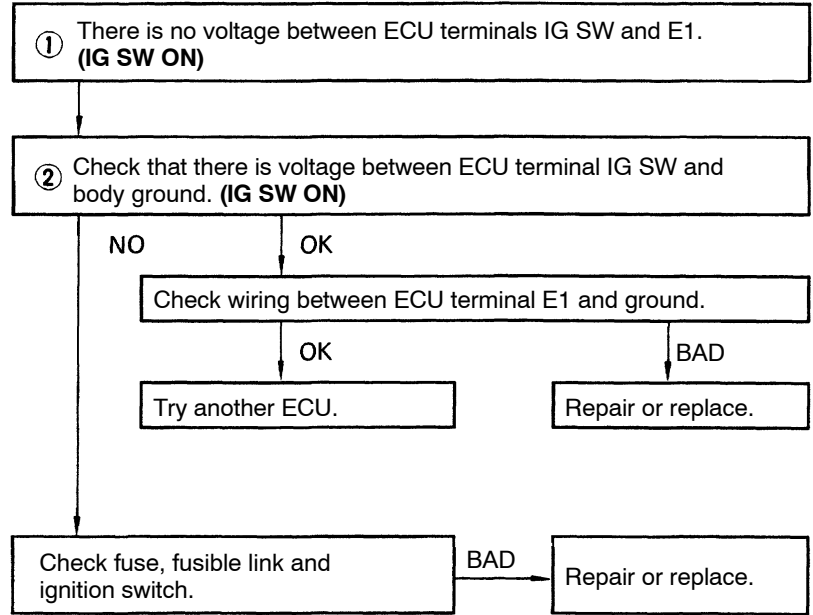

• M-REL - E1

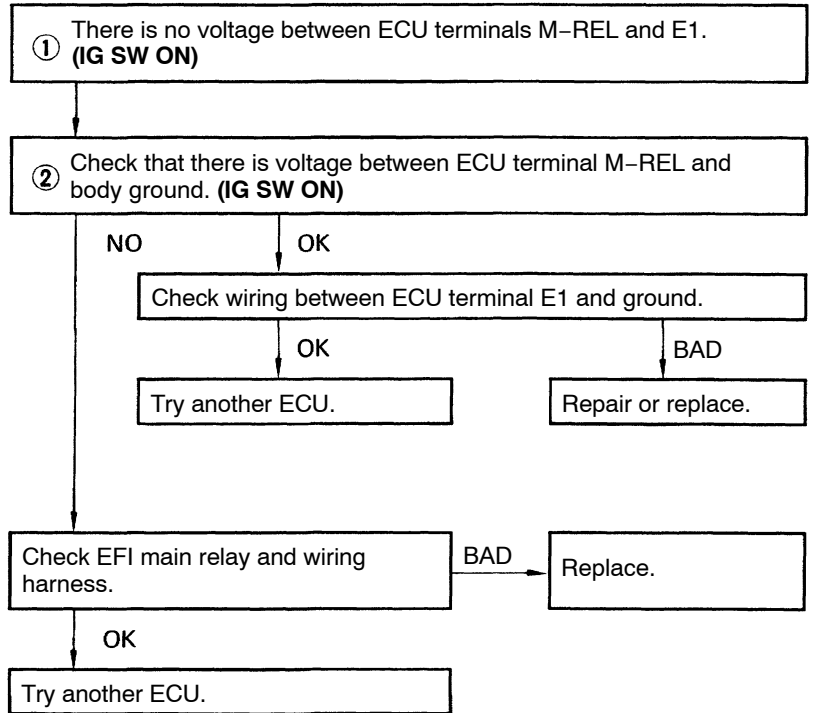

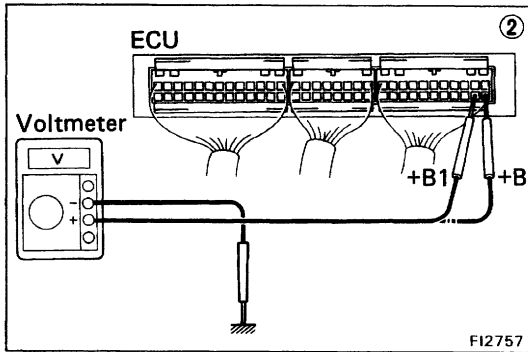
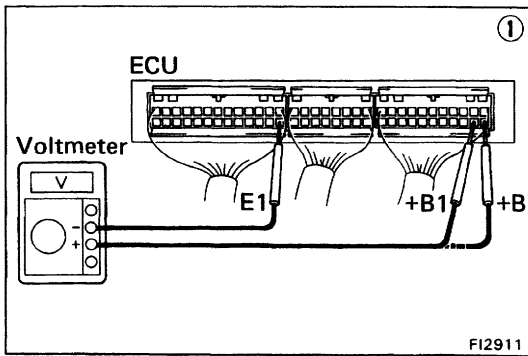

• +B (+B1) - E1

```

    graph TD
      Step1["① There is no voltage between ECU terminals + B (+ B1) and E1. (IG SW ON)"]
      Step2["② Check that there is voltage between ECU terminal +B (+ B1) and body ground. (IG SW ON)"]
      CheckWiring["Check wiring between ECU terminal E1 and ground."]
      CheckFuse["Check fuse, fusible link and wiring harness."]
      CheckRelay["Check EFI main relay. (See page FI-76)"]
      ReferMREL["Refer to M-REL - E1 trouble section."]
      TryECU["Try another ECU."]
      RepairECU["Repair or replace."]
      RepairFuse["Repair or replace."]
      ReplaceRelay["Replace."]

      Step1 --> Step2
      Step2 -- NO --> CheckFuse
      Step2 -- OK --> CheckWiring
      CheckWiring -- OK --> TryECU
      CheckWiring -- BAD --> RepairECU
      CheckFuse -- OK --> CheckRelay
      CheckFuse -- BAD --> RepairFuse
      CheckRelay -- OK --> ReferMREL
      CheckRelay -- BAD --> ReplaceRelay
  
```

The flowchart provides a systematic approach to troubleshooting a no-voltage condition between ECU terminals +B (+B1) and E1. It starts with a basic voltage check and branches into several diagnostic paths based on the results of each step.

No.	Terminals	Trouble	Condition	STD Voltage	
2	IDL - E2	No voltage	Ignition SW ON	Throttle valve open	4 - 6 V
	VC - E2			-	4 - 6 V
	VTA - E2			Throttle valve fully closed	0.1 - 1.0 V
				Throttle valve fully open	3.2 - 4.2 V

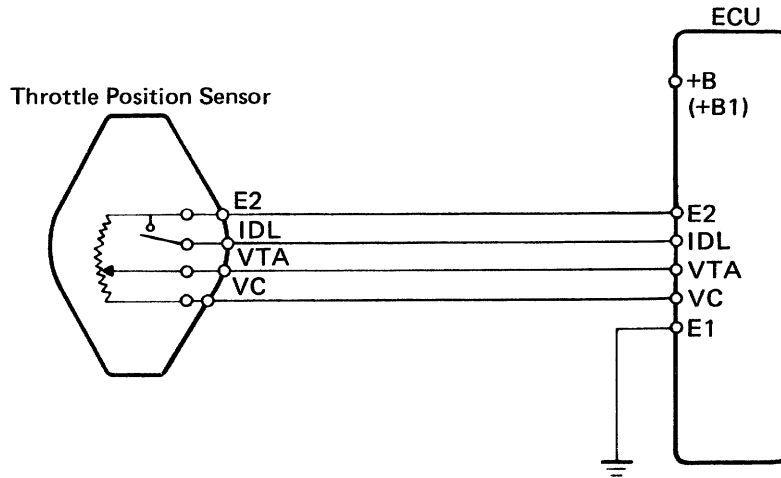

FI6031

• IDL - E2

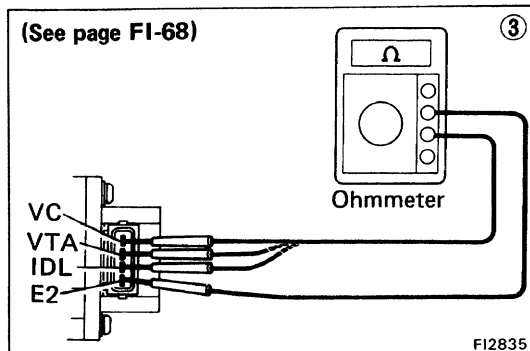
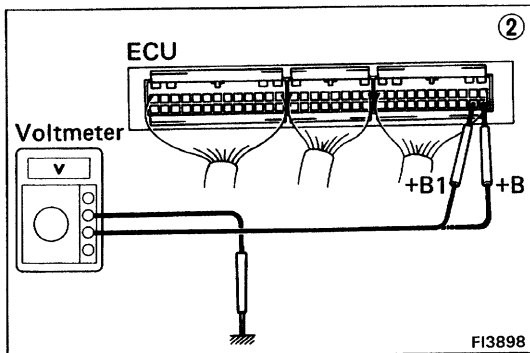
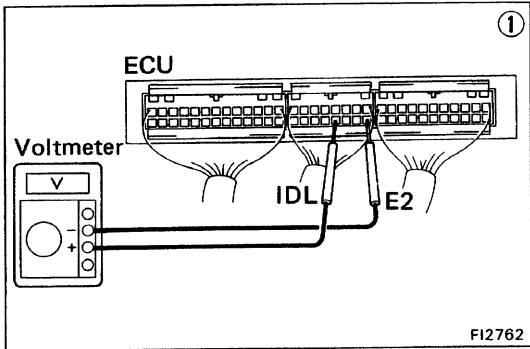

```

    graph TD
      Step1["① There is no voltage between ECU terminals IDL and E2.  
(IG SW ON) (Throttle valve open)"]
      Step2["② Check that there is voltage between ECU terminal +B (+B1)  
and body ground. (IG SW ON)"]
      Step3["③ Check throttle position sensor."]
      
      Step1 --> Step2
      Step2 -- NO --> CheckE1["Check wiring between ECU terminal E1 and body  
ground."]
      Step2 -- OK --> ReferNo1["Refer to No.1.  
(See page FI-34)"]
      CheckE1 -- OK --> TryECU["Try another ECU."]
      CheckE1 -- BAD --> RepairECU["Repair or replace."]
      ReferNo1 -- BAD --> RepairECU
      ReferNo1 -- OK --> Step3
      Step3 -- BAD --> RepairSensor["Repair or replace throttle  
position sensor."]
      Step3 -- OK --> CheckWiring["Check wiring between ECU  
and throttle position sensor."]
      CheckWiring -- OK --> TryECU2["Try another ECU."]
      CheckWiring -- BAD --> RepairECU
  
```

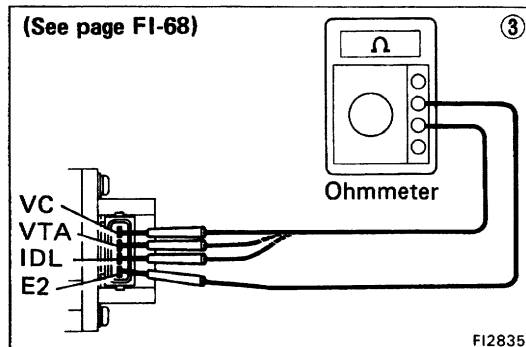
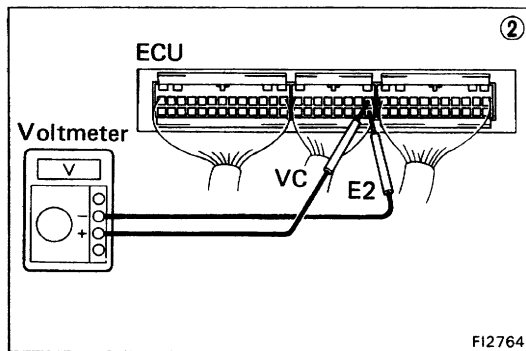
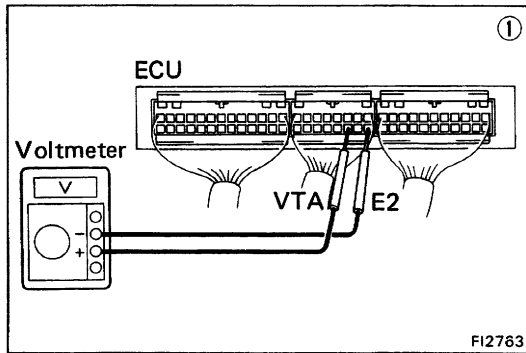
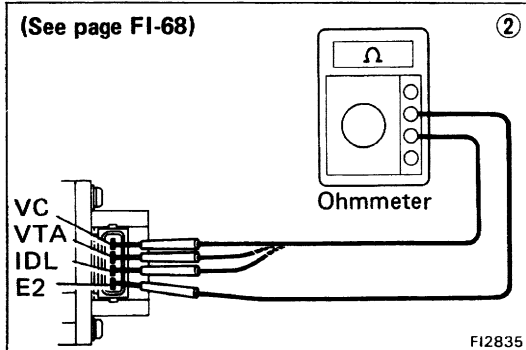
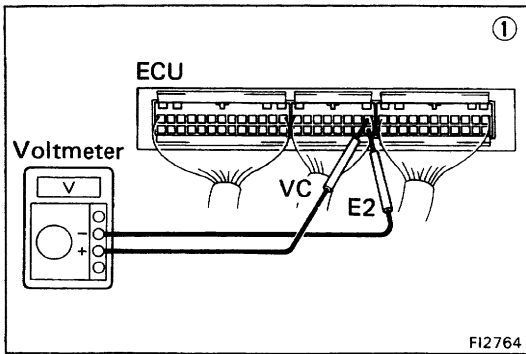

• VC - E2

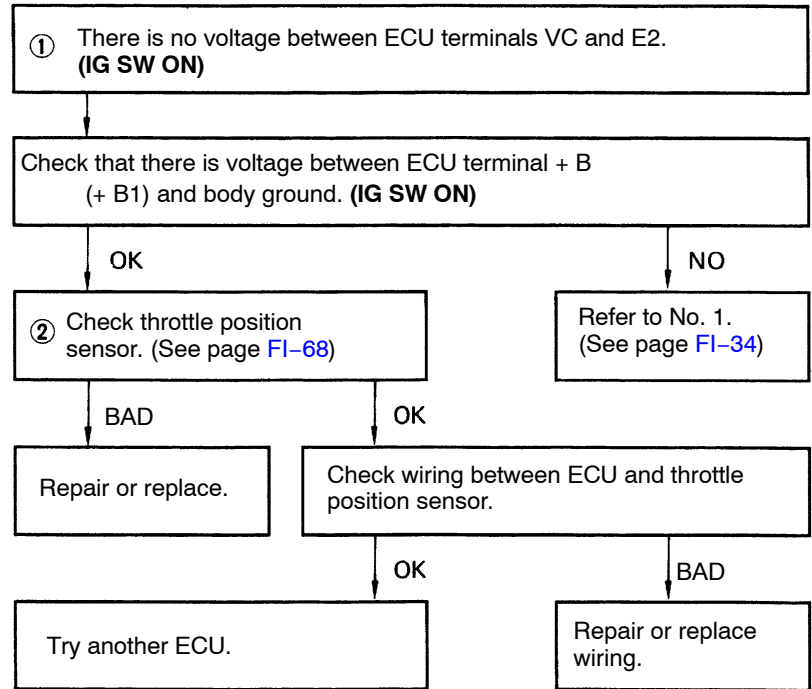

• VTA-E2

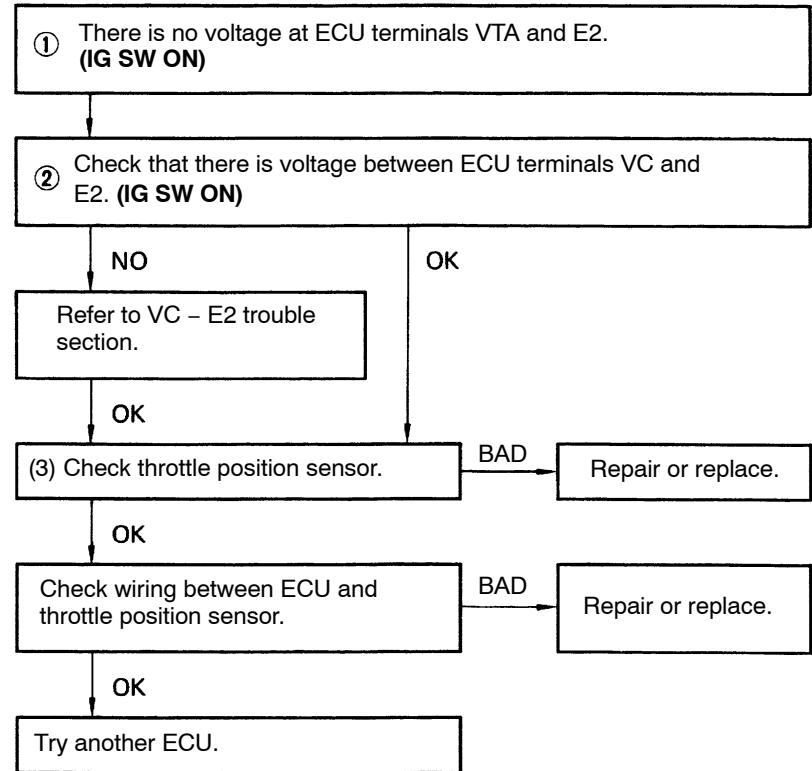

No.	Terminals	Trouble	Condition		STD Voltage
3	VC - E2	No voltage	Ignition SW ON	-	4 - 6 V
	VS - E2			Measuring plate fully closed	3.7 - 4.3 V
			Measuring plate fully open	0.2 - 0.5 V	
			Idling	-	2.3 - 2.8 V
	3,000 rpm	-	1.0 - 2.0 V		

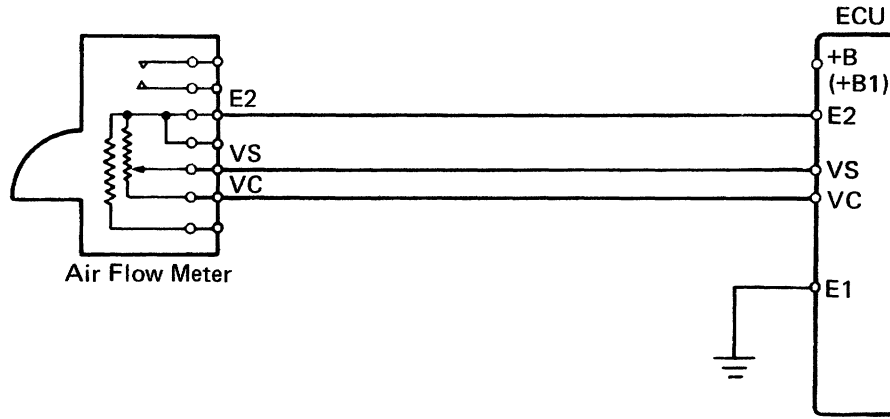

FI6032

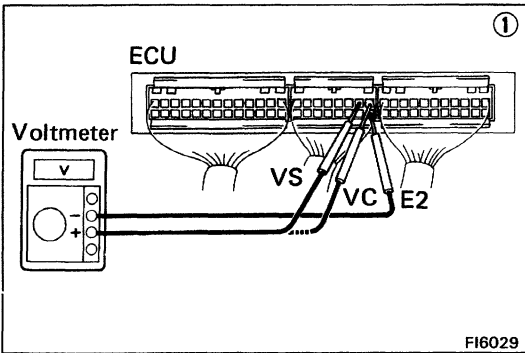

FI6029

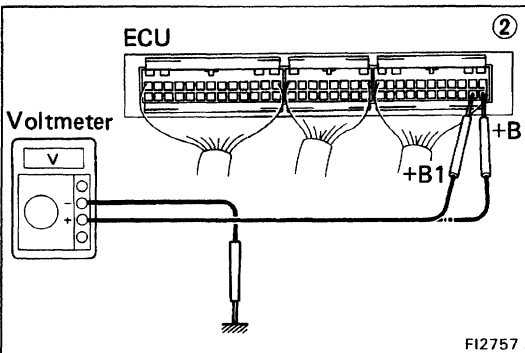

FI2757

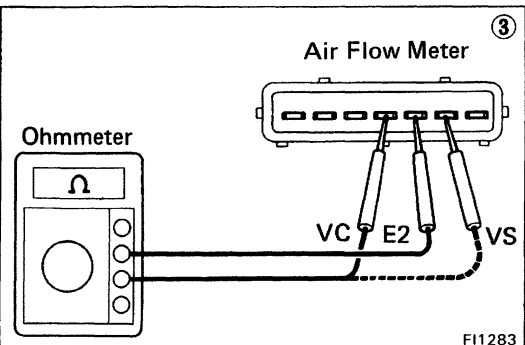

FI1283

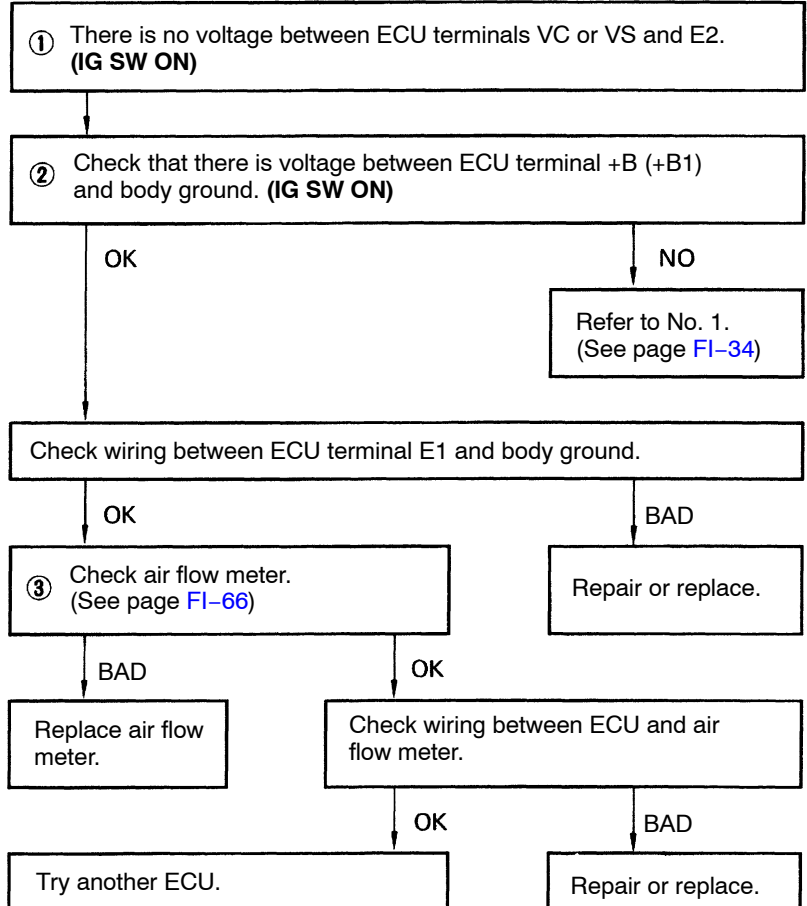

No.	Terminals	Trouble	Condition	STD Voltage
4	No.10 No.20 — E01 No.30 — E02	No voltage	Ignition SW ON	10 — 14 V

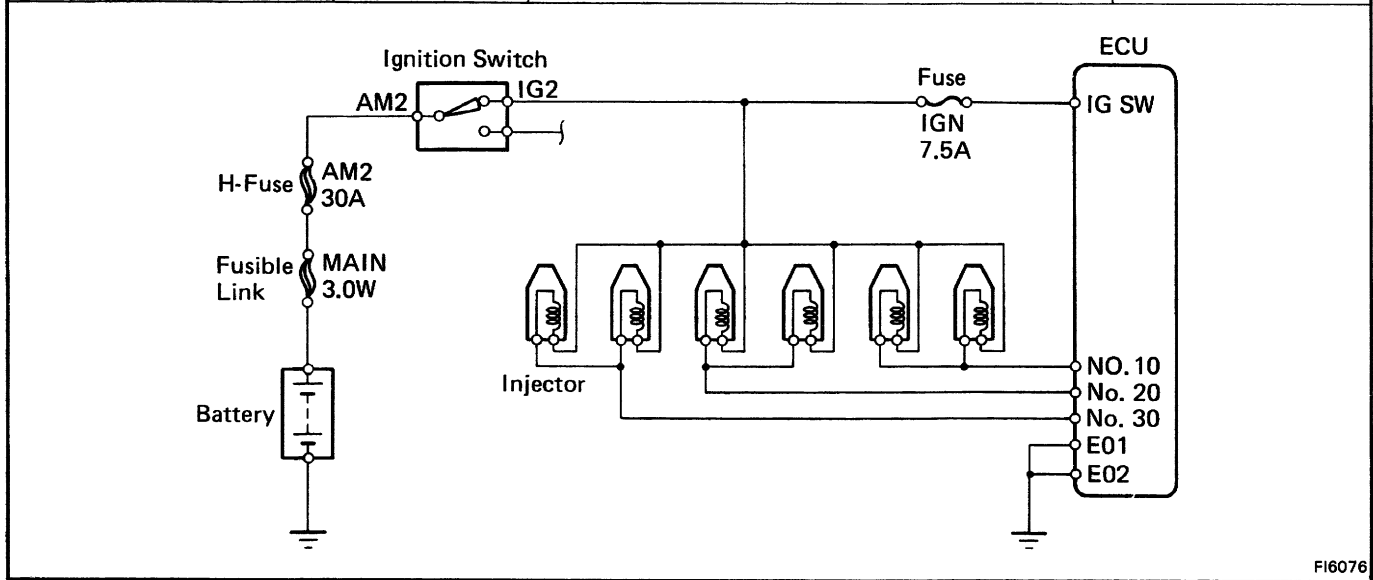

FI6076

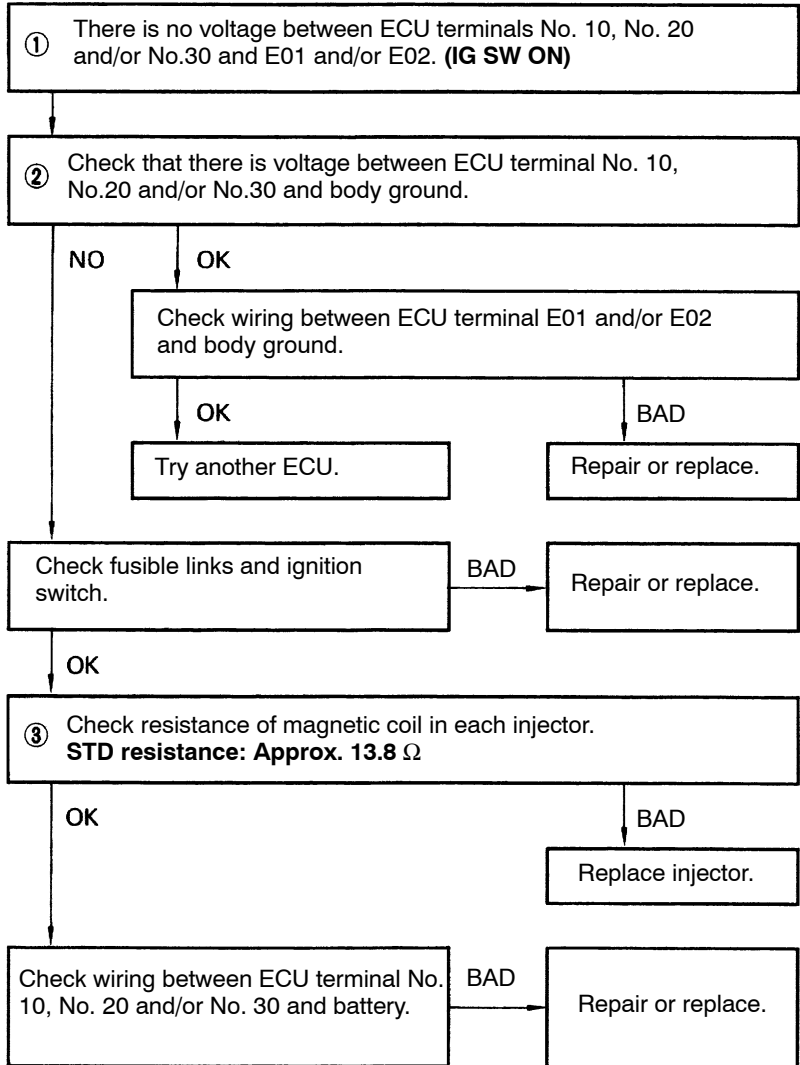
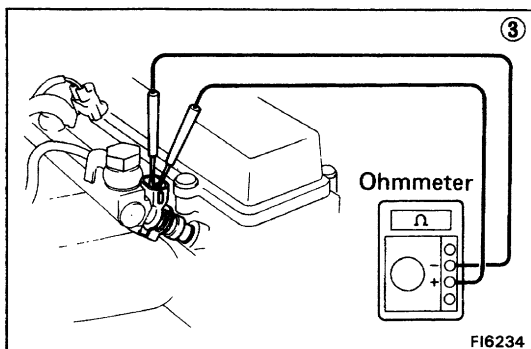
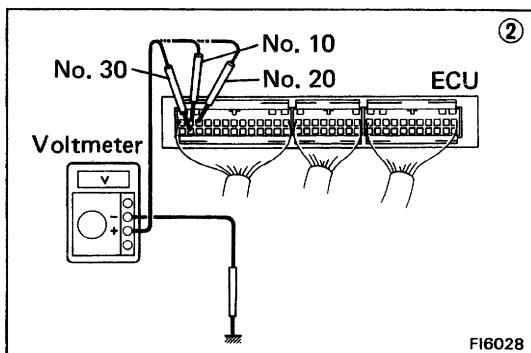
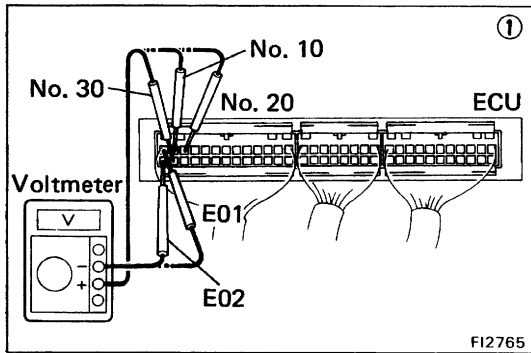

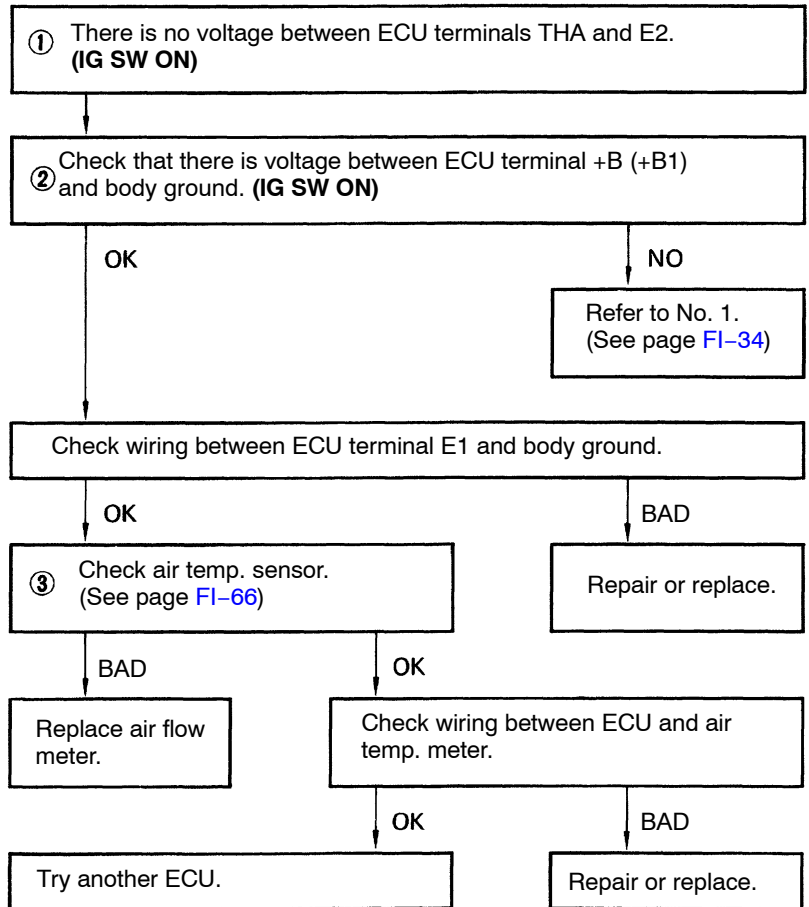
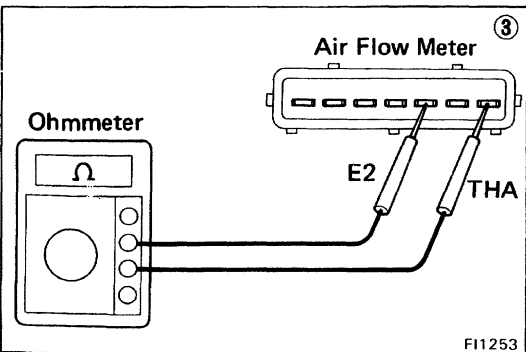
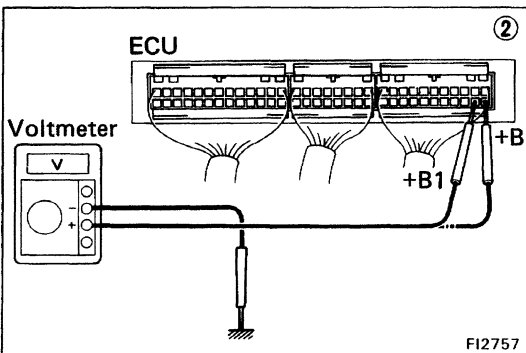
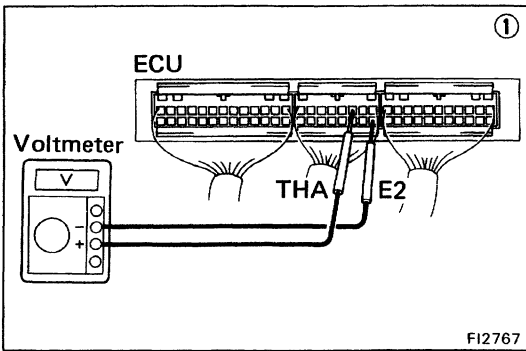
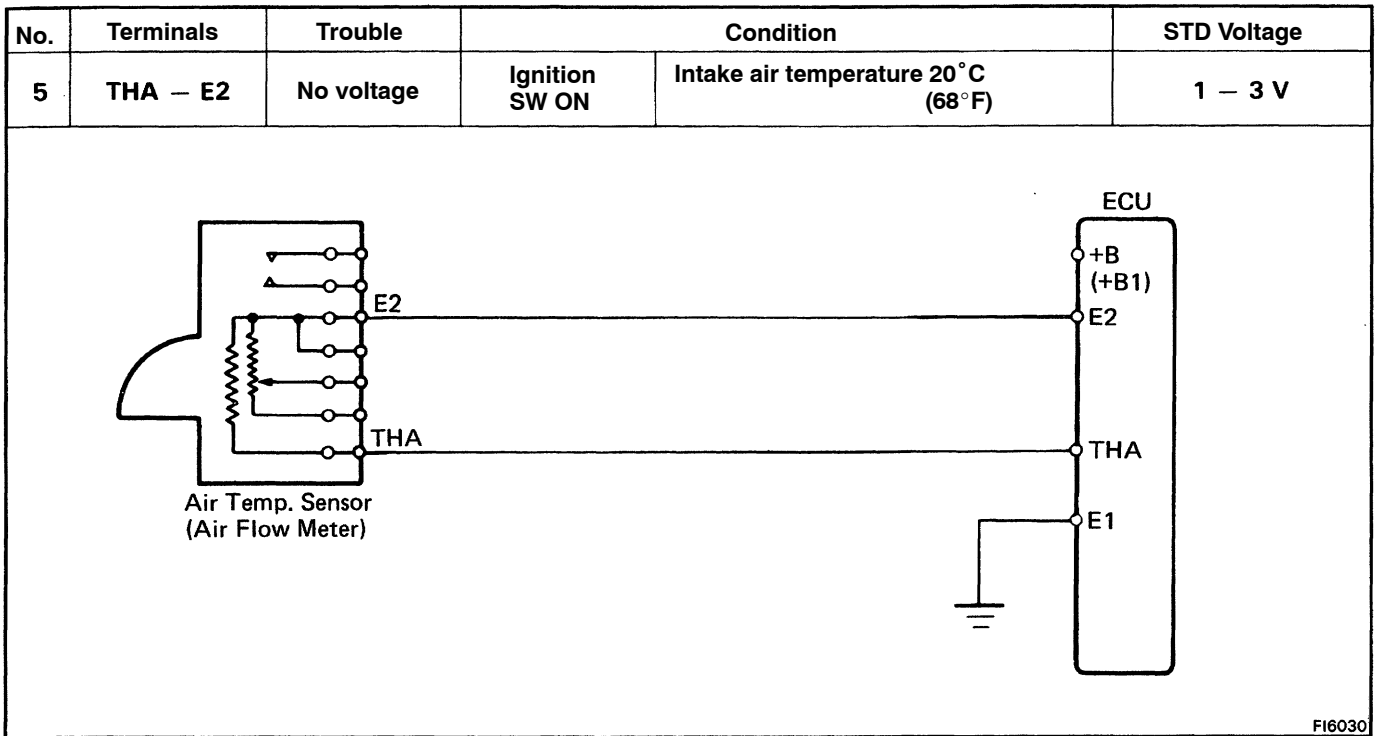

No.	Terminals	Trouble	Condition		STD Voltage
6	THW - E2	No voltage	Ignition SW ON	Coolant temperature 80°C (176°F)	0.1 - 1.0 V

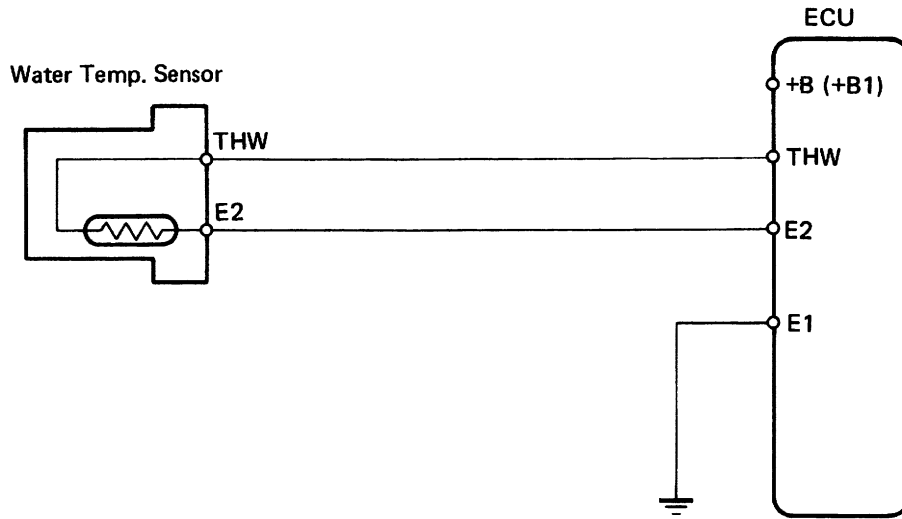

FI3572

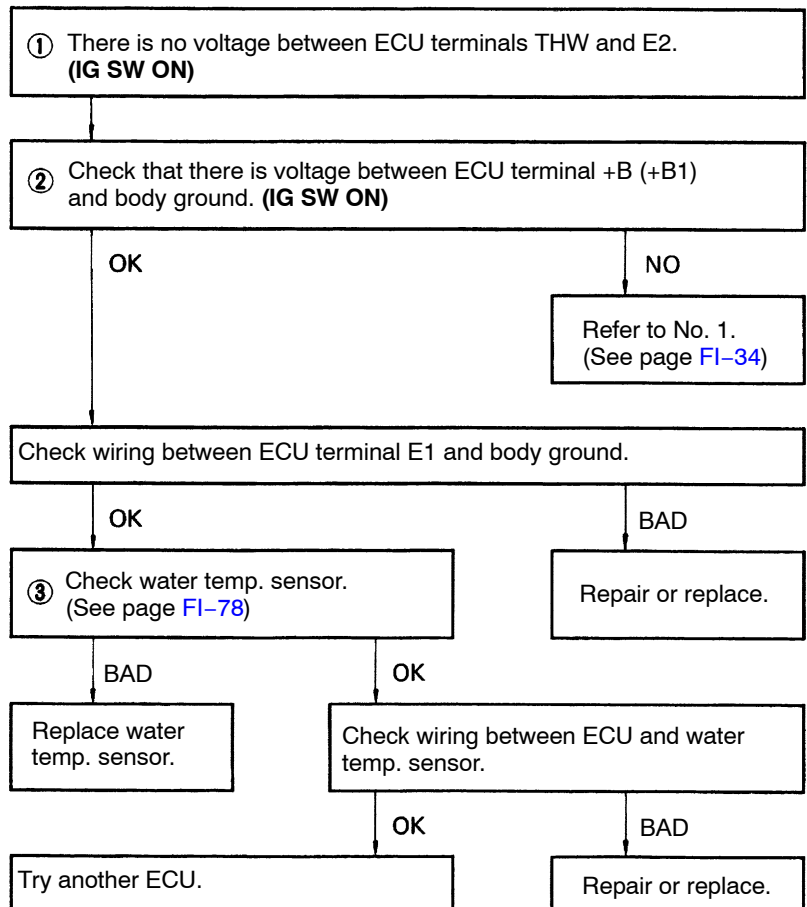
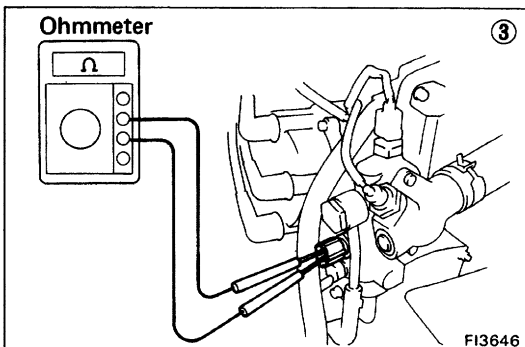
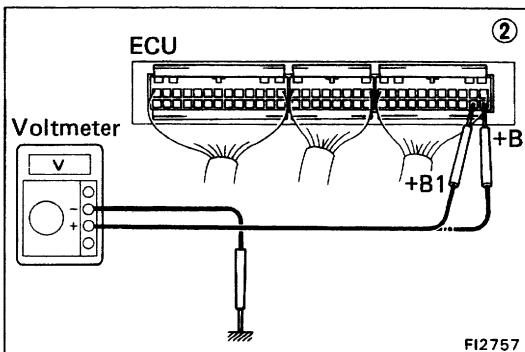
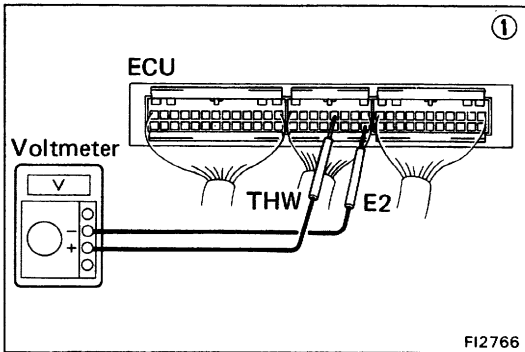

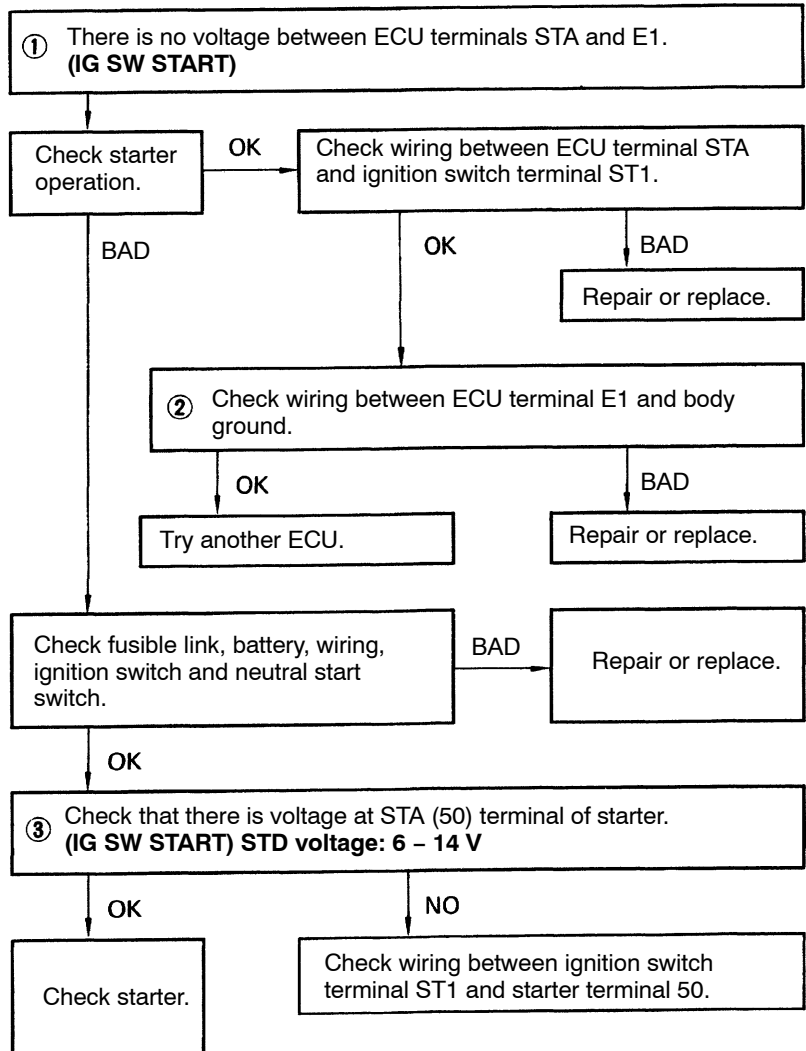
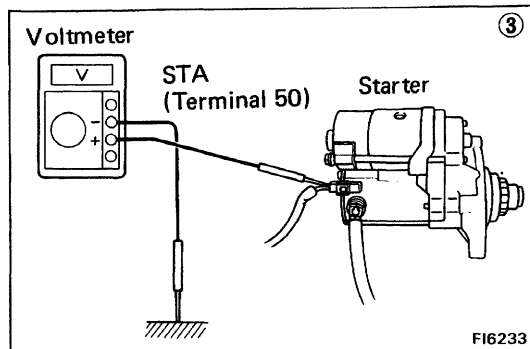
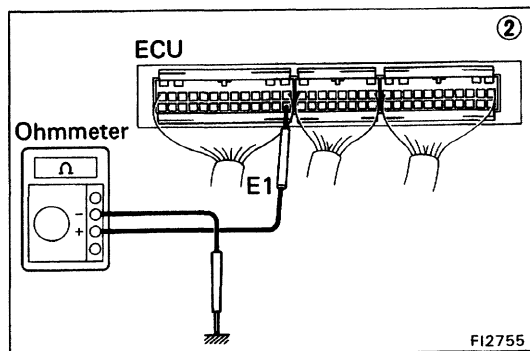
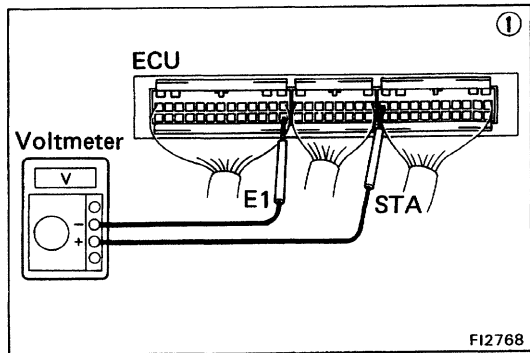
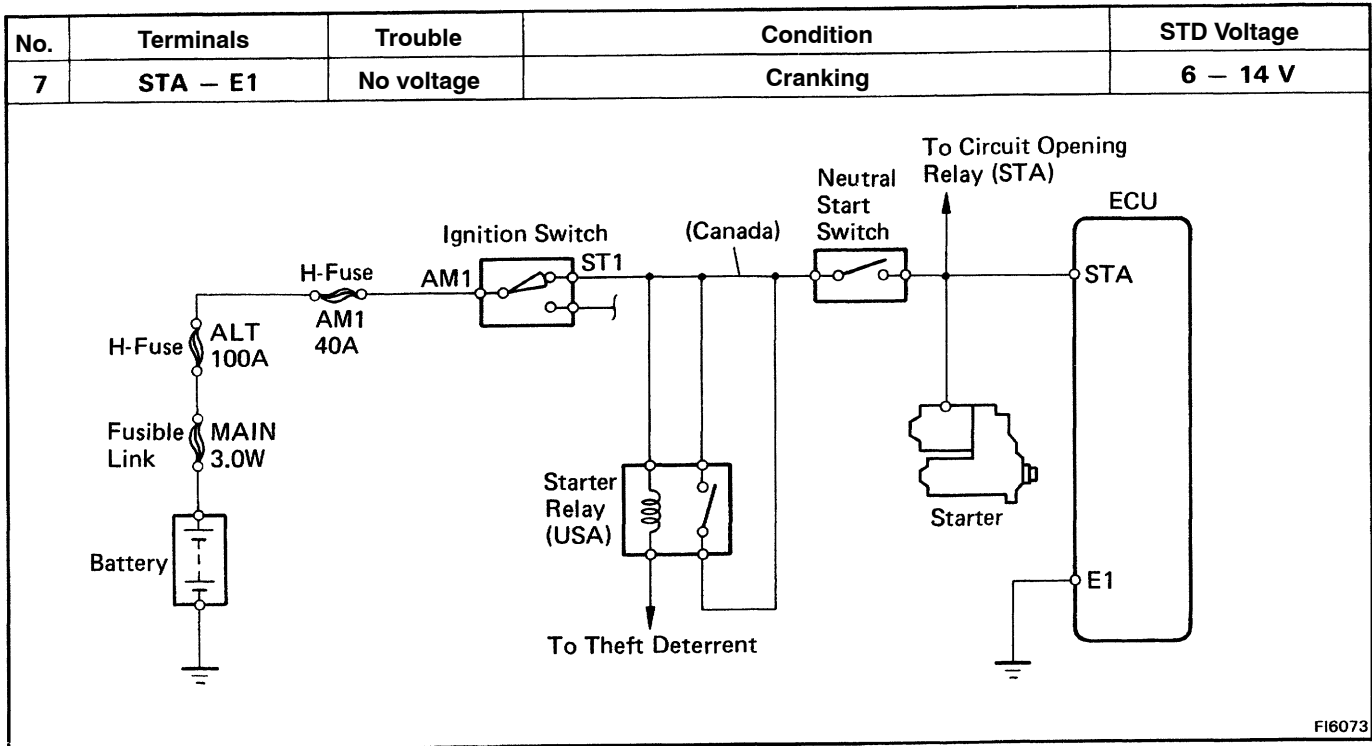

No.	Terminals	Trouble	Condition	STD Voltage
8	IGT - E1	No voltage	Idling	0.7 - 1.0 V

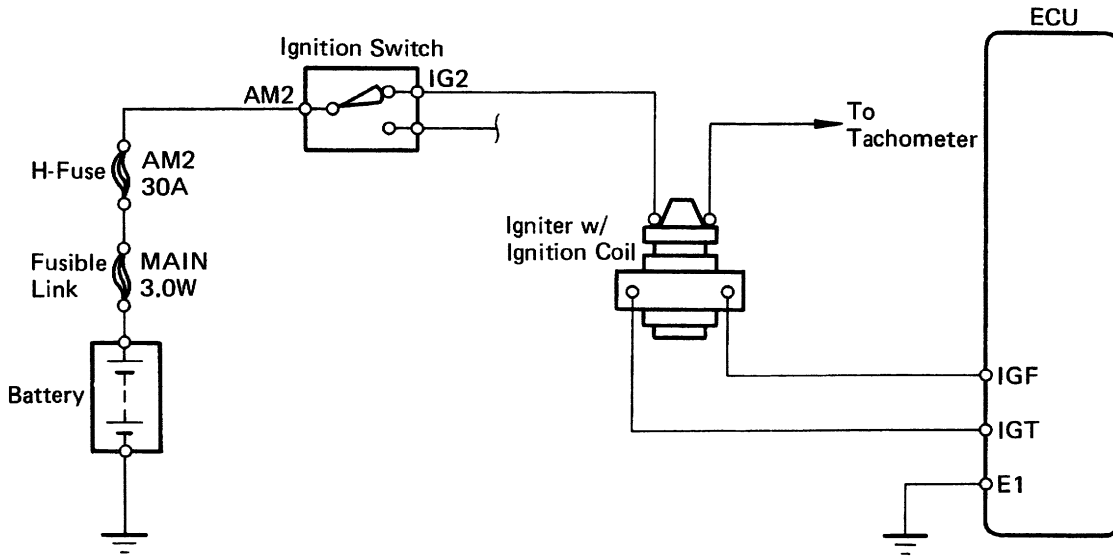

FI6072

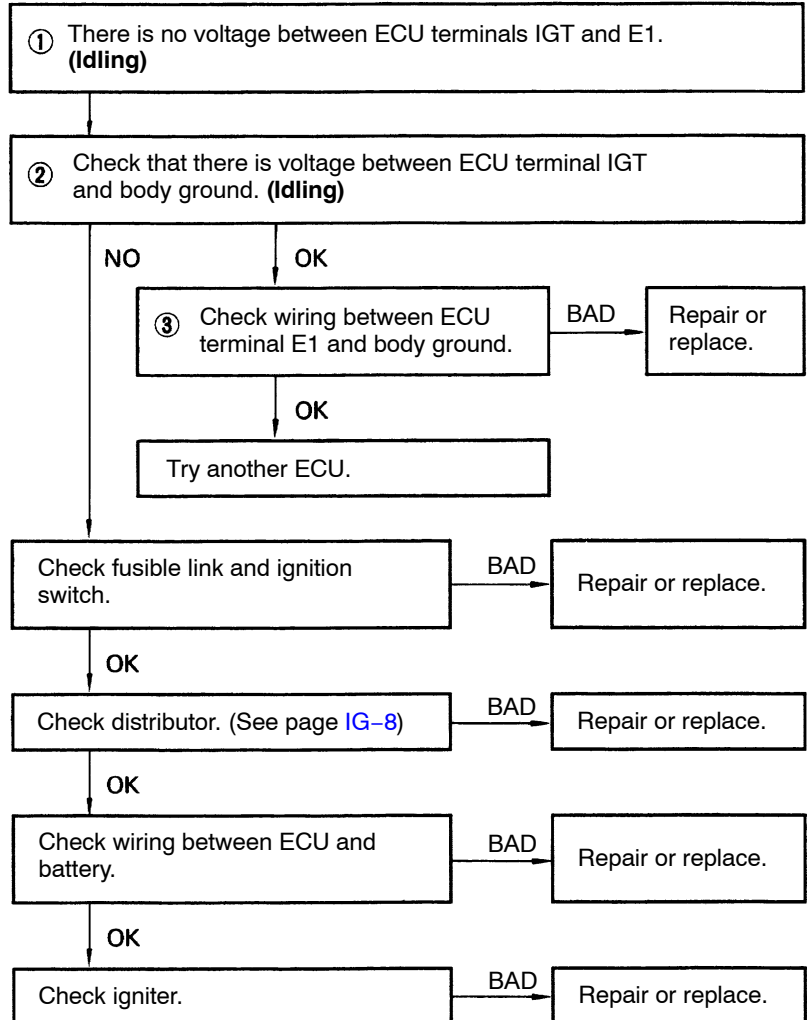
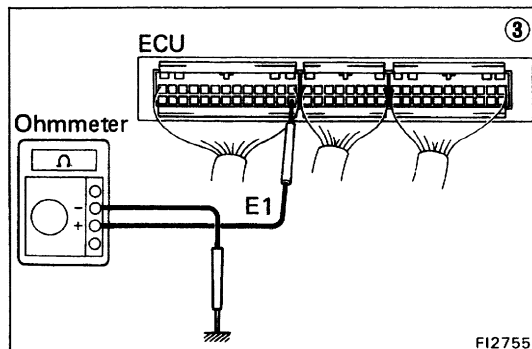
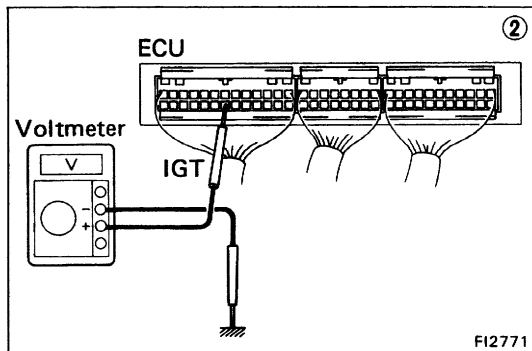
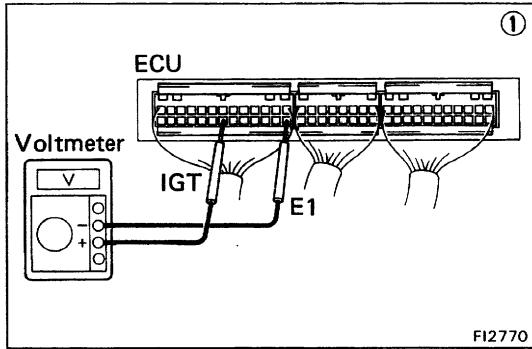

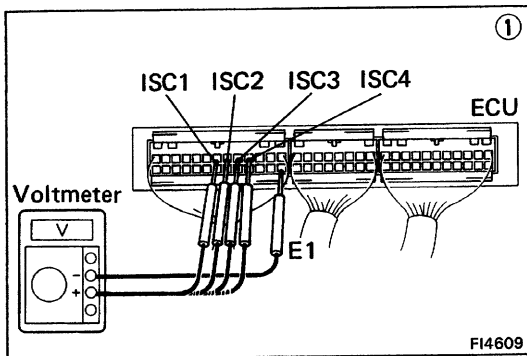
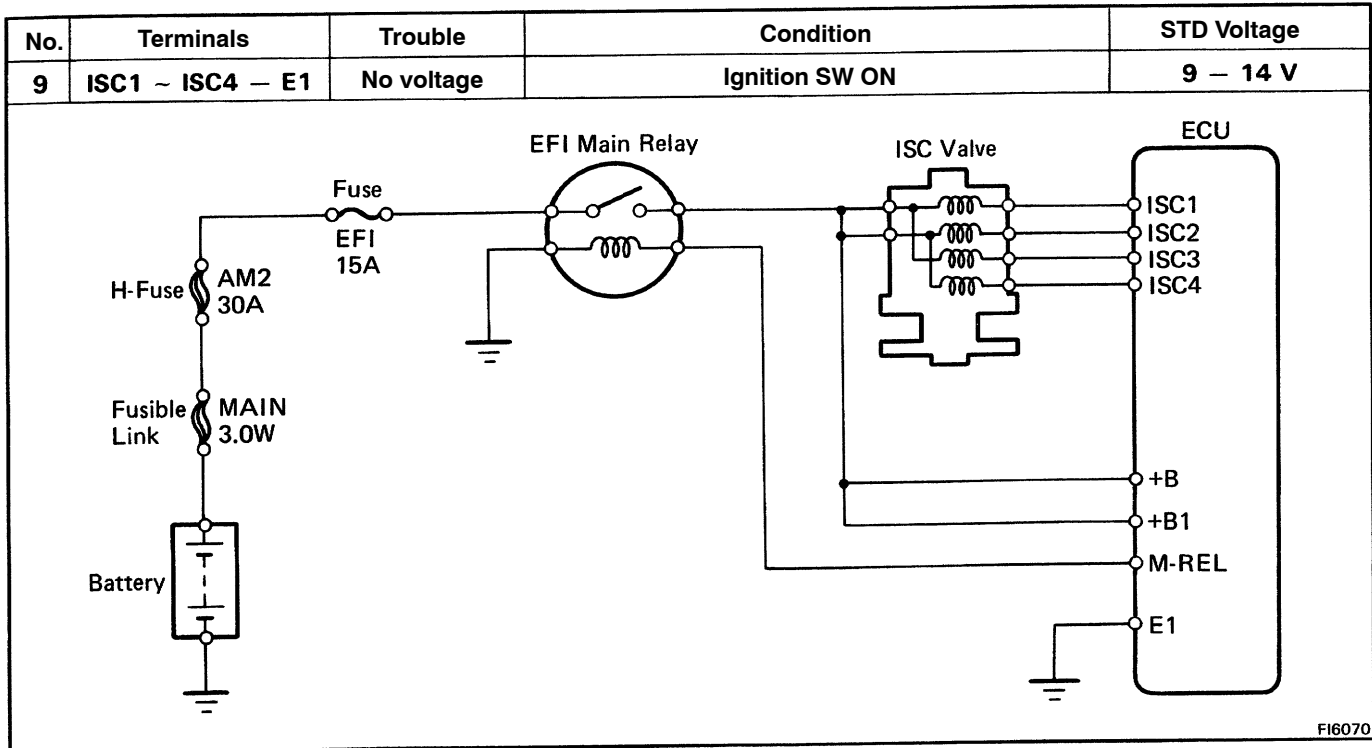

① There is no voltage between ECU terminals ISC1 - ISC4 and E1. (IG SW ON)

② Check that there is voltage between ECU terminal +B (+B1) and body ground. (IG SW ON)

OK

NO

Refer to No. 1. (See page FI-34)

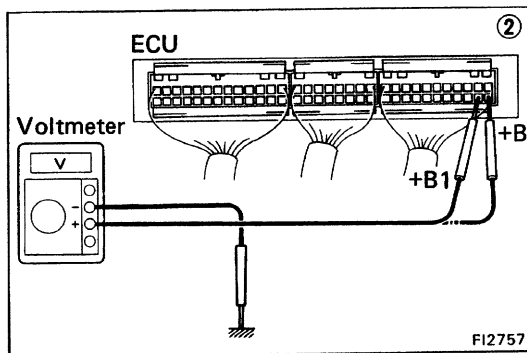

Check wiring between ECU terminal E1 and body ground.

OK

BAD

③ Check ISV valve. (See page FI-73)

Repair or replace.

BAD

OK

Replace ISC valve.

Check wiring between ECU and EFI main relay.

OK

BAD

Try another ECU.

Repair or replace.

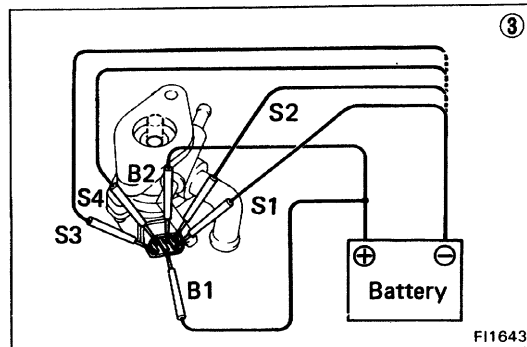

No.	Terminals	Trouble	Condition	STD Voltage
10	W - E1	No voltage	No trouble ("CHECK" engine warning light off) and engine running	8 - 14 V

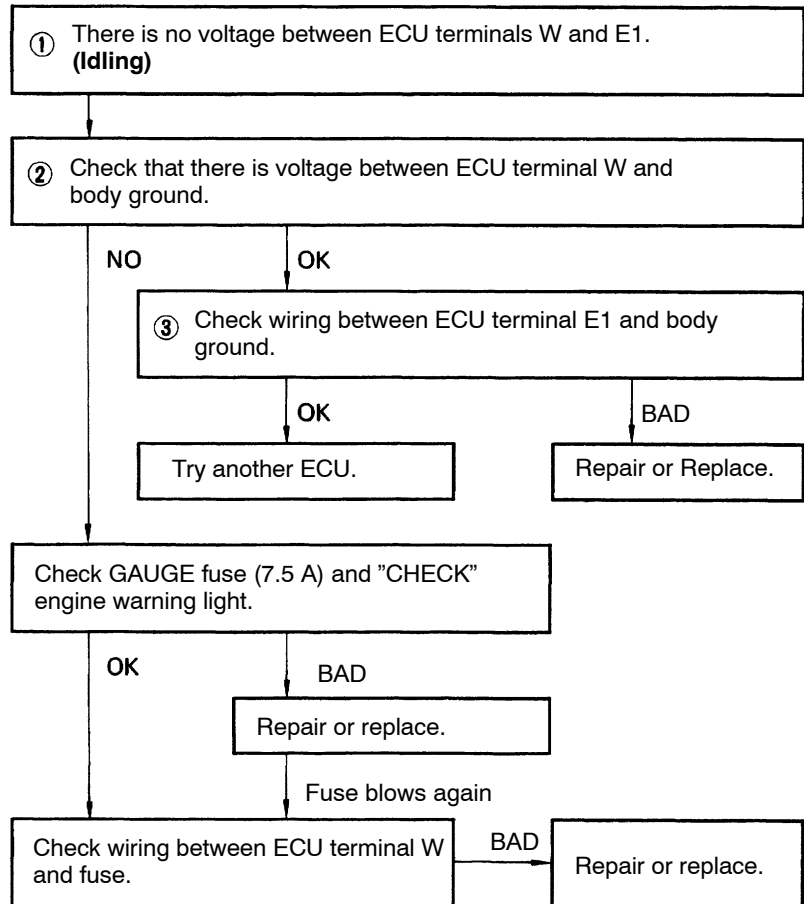
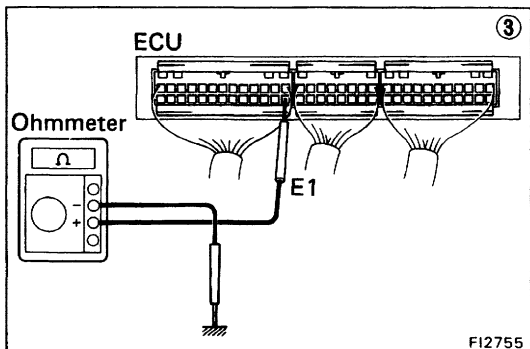
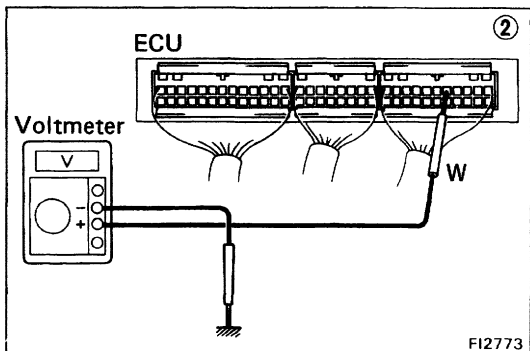
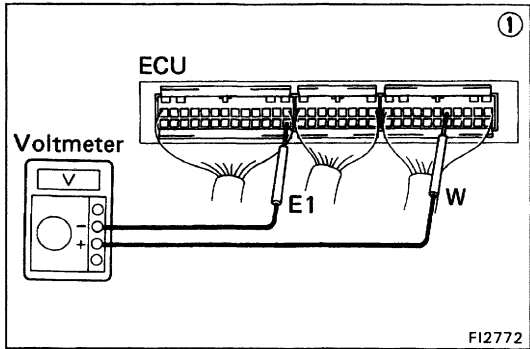
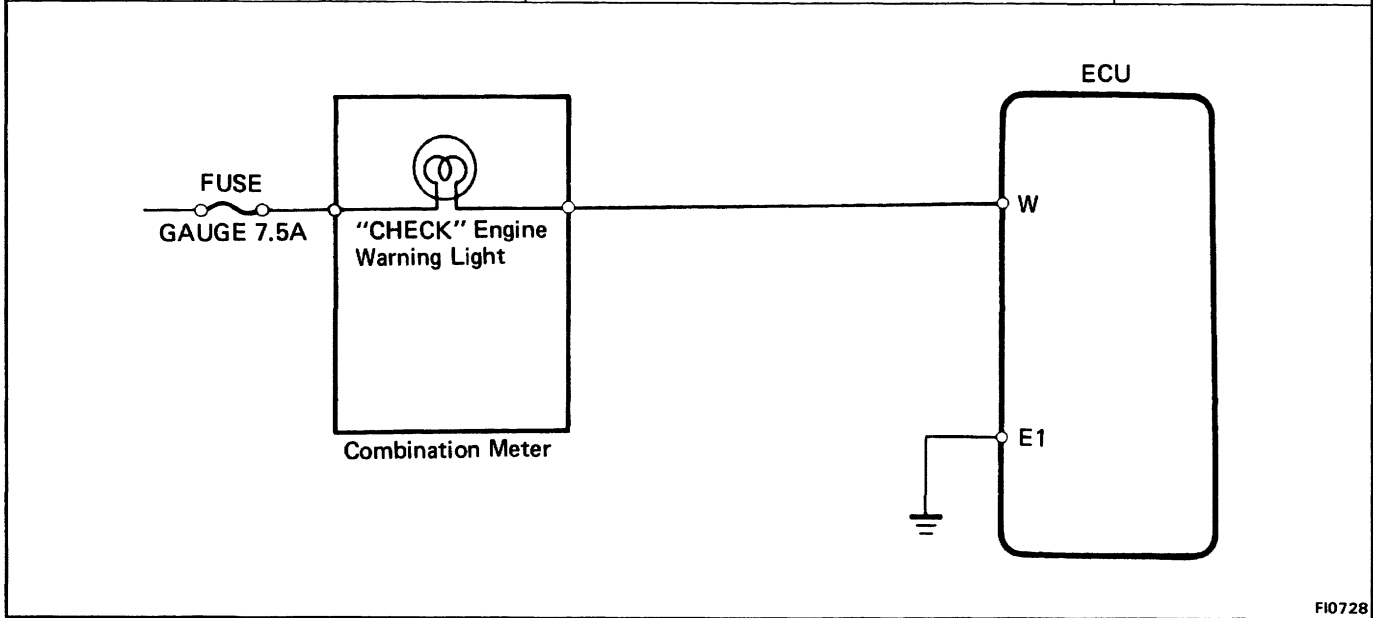

No.	Terminals	Trouble	Condition		STD Voltage
11	A/C - E1	No voltage	Ignition SW ON	Air conditioning ON	10 - 14 V

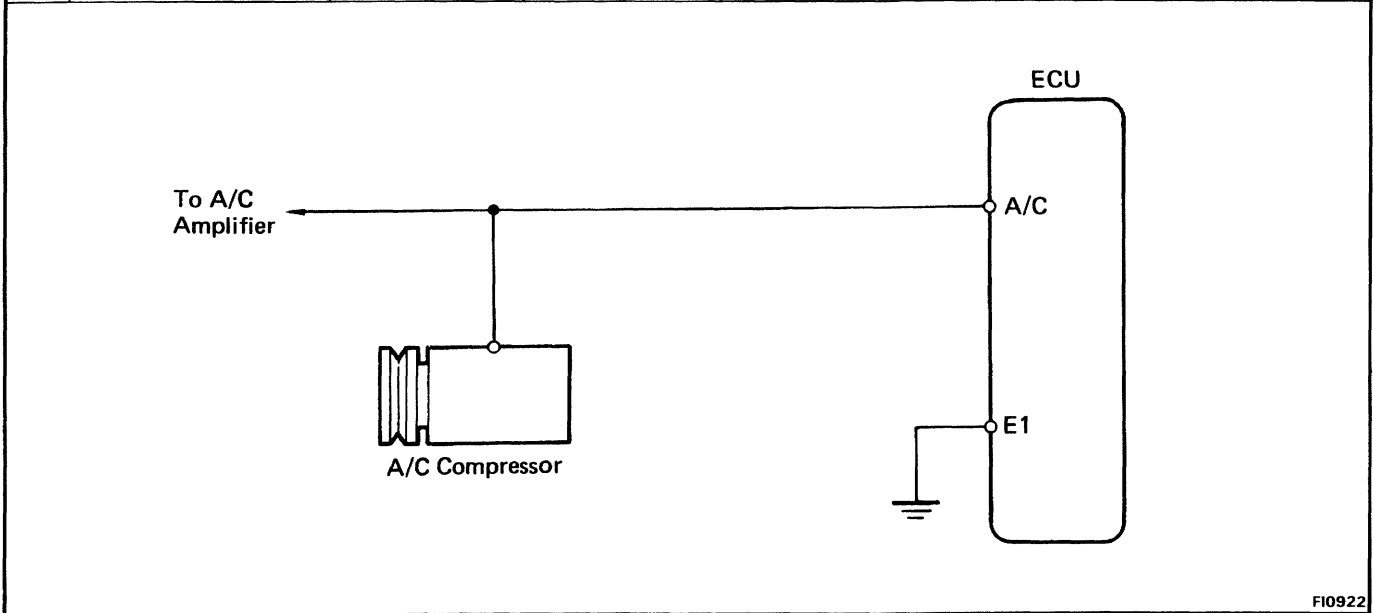

FI0922

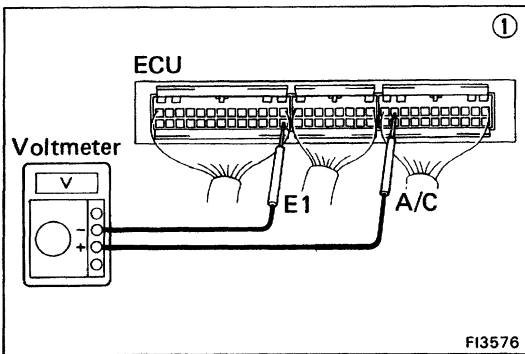

FI3576

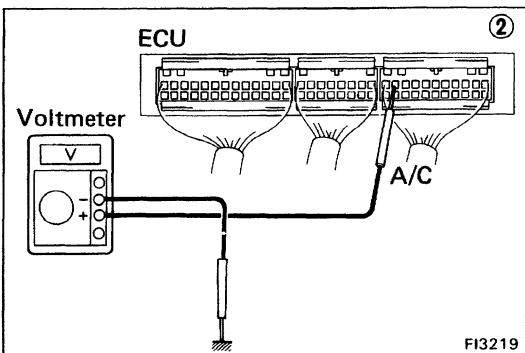

FI3219

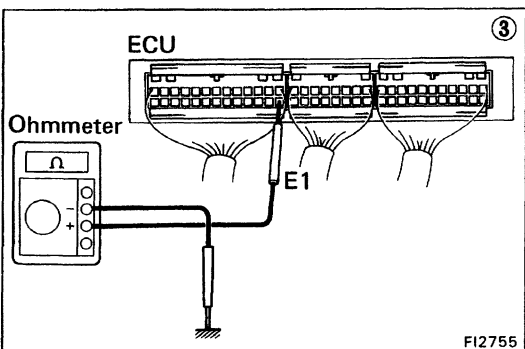

FI2755

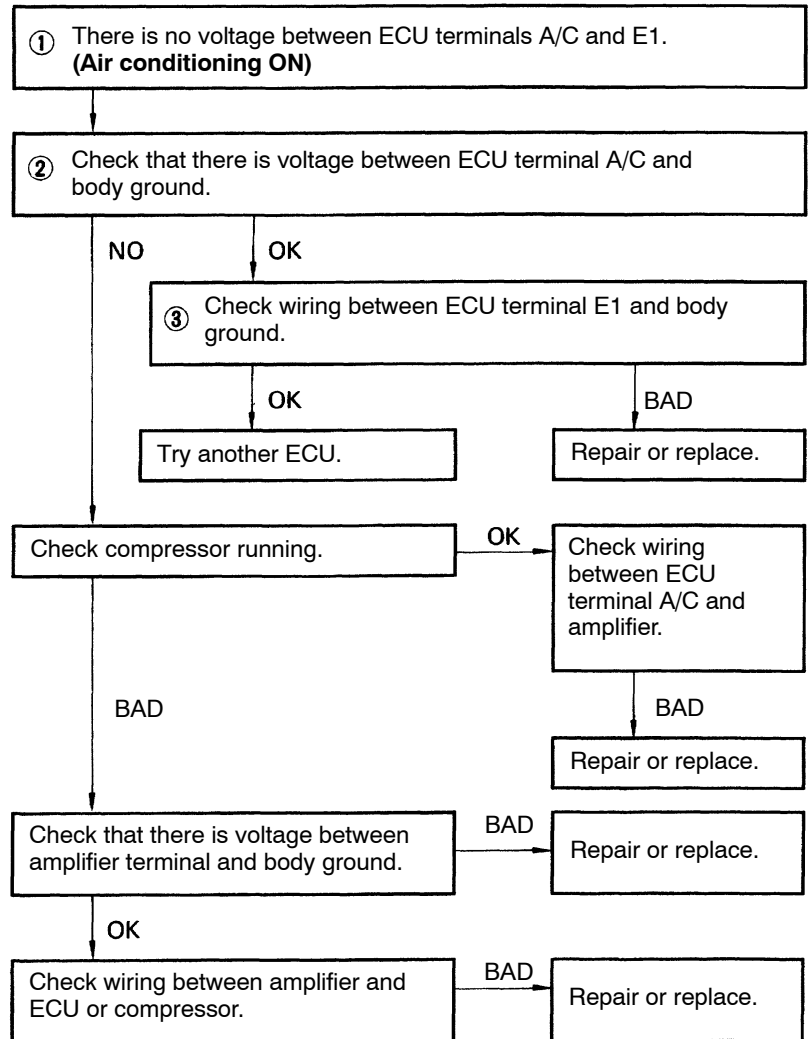

California Specification Vehicles only

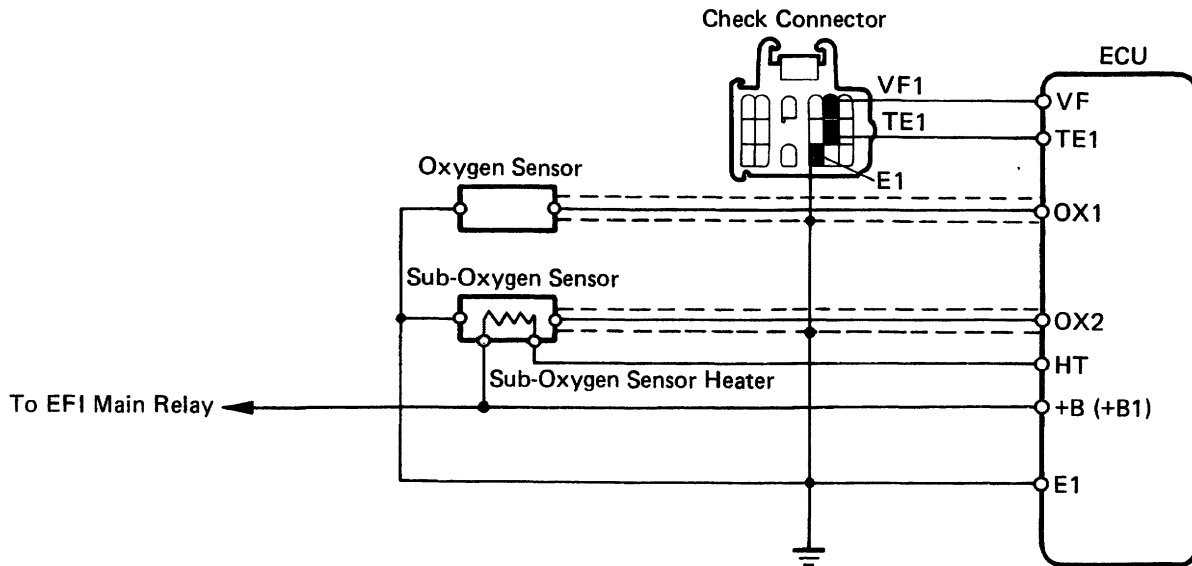

FI6033

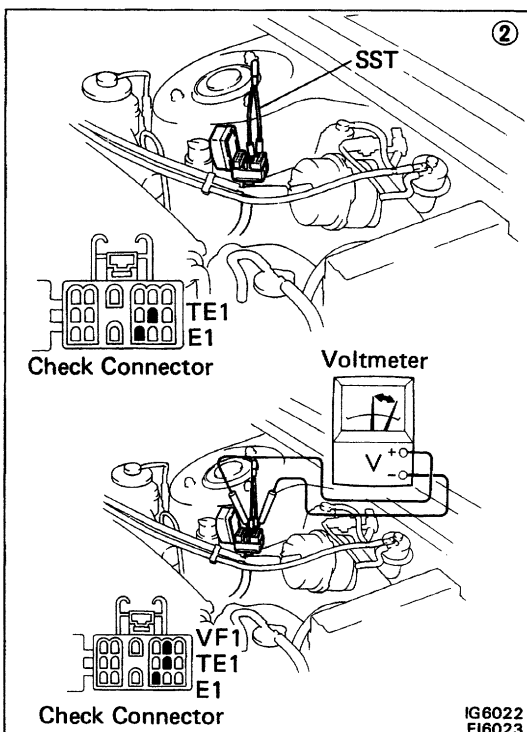
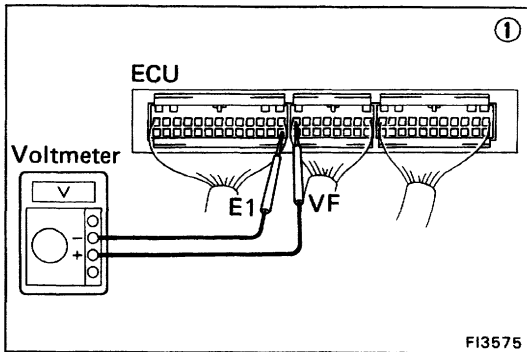

```

    graph TD
      A["(1) There is no voltage between ECU terminals VF and E1."] --> B["Check that there is specified voltage between ECU terminal VF and body ground."]
      B -- NO --> C["Check wiring between ECU terminal E1 and body ground."]
      B -- OK --> D["Check for suction of air into exhaust system."]
      C -- OK --> E["Try another ECU."]
      C -- BAD --> F["Repair or replace."]
      D -- BAD --> G["Repair air suction."]
      D -- OK --> H["Check for air leak from air intake system."]
      H -- BAD --> I["Repair air leak."]
      H -- OK --> J["Check spark plugs."]
      J -- BAD --> K["Repair or replace."]
      J -- OK --> L["Check distributor and ignition system."]
      L -- BAD --> M["Repair or replace."]
      L -- OK --> N["Check fuel pressure."]
      N -- BAD --> O["Repair or replace."]
      N -- OK --> P["Check injectors."]
      P -- BAD --> Q["Repair or replace."]
      P -- OK --> R["Check cold start injector.*"]
      R -- BAD --> S["Repair or replace."]
      R -- OK --> T["Check air flow meter."]
      T -- BAD --> U["Repair or replace."]
      T -- OK --> V["Check operation of oxygen sensors."]
      V -- OK --> W["System normal."]
      V -- BAD --> X["Check wiring between oxygen sensors and ECU connectors."]
      X -- BAD --> Y["Repair wiring."]
      X -- OK --> Z["Repair oxygen sensors."]
  
```

* Rich malfunction only.

California Specification Vehicles Only

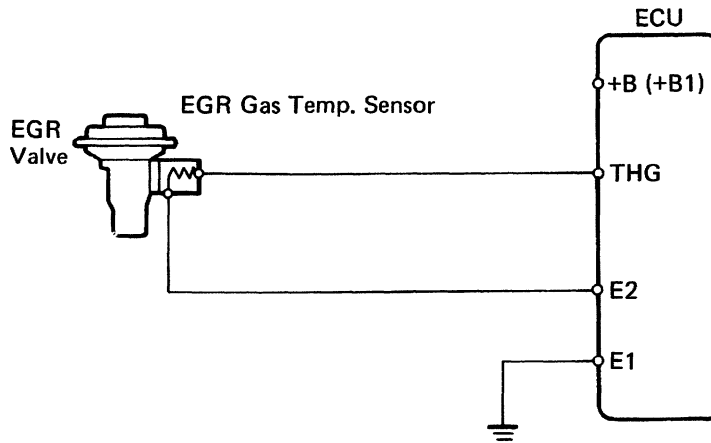

FI2680

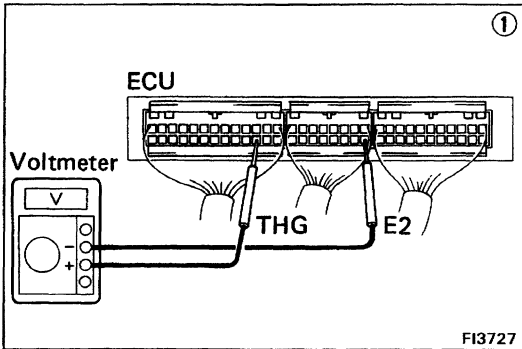

FI3727

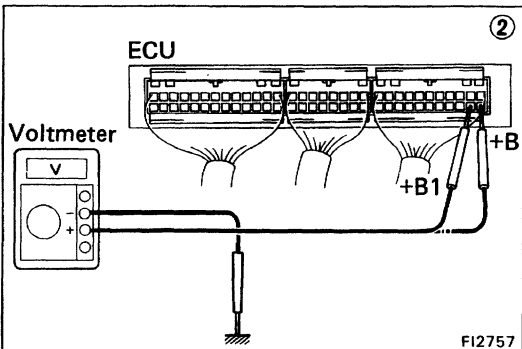

FI2757

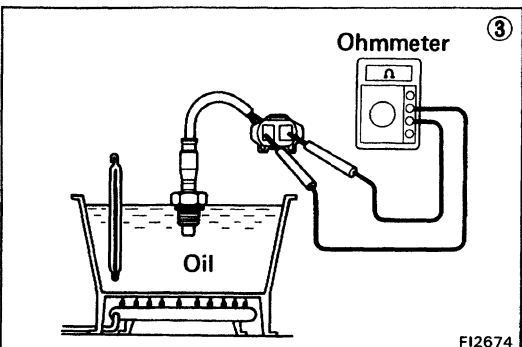

FI2674

