

WINDSHIELD PREPARE ITEMS LISTED

Part name and Part No.	Contents of set	Quantity
Adhesive set 08850-00070 [0 - 15°C (32 - 59°F)]	Main agent 500 g (17.64 oz.)	1
08850-00080 [15 - 35°C (59 - 95°F)]	Hardening agent 75 g (2.65 oz.)	1
08850-00090 [35 - 45°C (95 - 113°F)]	Primer G [for glass] 20 g (0.71 oz.)	1
	Primer M [for body] 20 g (0.71 oz.)	1
	Sponge for applying primer	2
	Piano wire 0.6 mm dia. x 1 m (0.024 in. dia x 39.37 in.)	1
	Cartridge	1
Dam kit 04562-30030	Dam Double-stick tape (for sticking on dam)	
	Sealant gun (for applying adhesive) Glass or steel sheet (for mixing adhesive) Putty spatula (for mixing adhesive and correcting adhered parts) Cleaner (for cleaning adhering surfaces)	

Ambient temperature	Part No.	Part name
0 - 15°C (32 - 59°F)	08850-00070	Windshield glass adhesive set No.15
15 - 35°C (59 - 95°F)	08850-00080	Windshield glass adhesive set No.35
35 - 45°C (95 - 113°F)	08850-00090	Windshield glass adhesive set No.45

1. CHOOSE SUITABLE ADHESIVE SET

Use an adhesive set suitable for the ambient temperature.

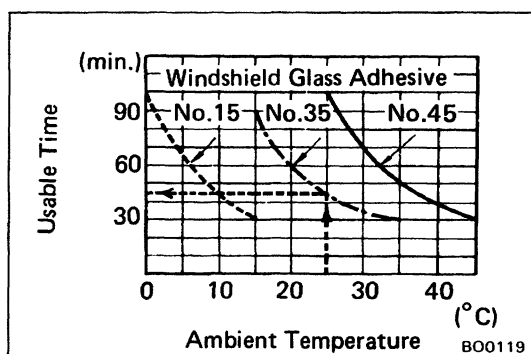

2. CHECK ADHESIVE USABLE TIME

After mixing main and hardening agents, finish glass installation within the specified time as shown.

Example: For glass installation in an ambient temperature of 25°C (77°F), apply adhesive set No. 35 within 45 minutes.

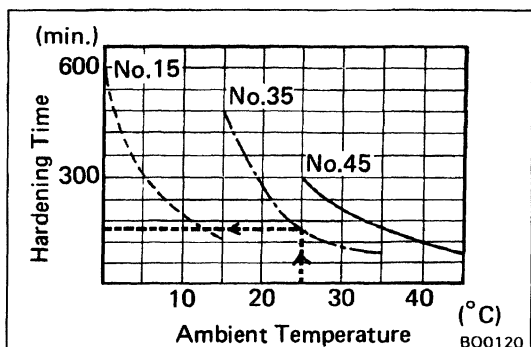

3. CHECK ADHESIVE HARDENING TIME

After main and hardening agents are mixed, leak tests should be made only after the hardening time has elapsed.

Example: The hardening time for adhesive set No. 35 with an ambient temperature of 25°C (77°F) is 2 1/2 hours.

NOTICE: Do not drive the vehicle until at least double the hardening time has elapsed.

COMPONENTS

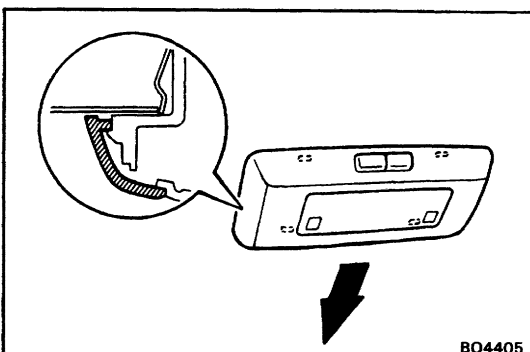
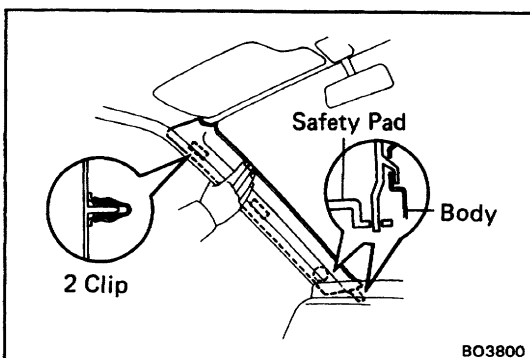
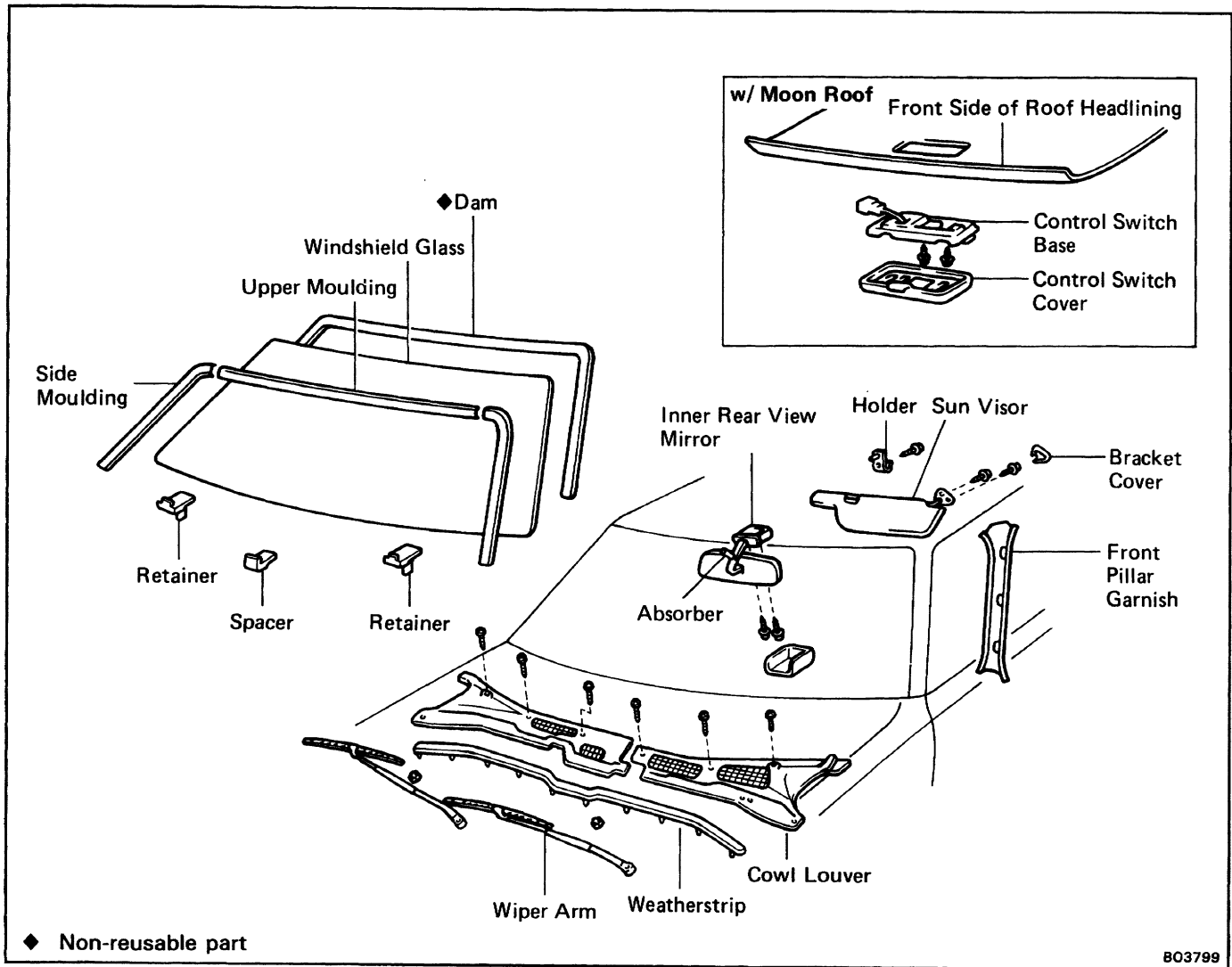

REMOVAL OF WINDSHIELD

1. REMOVE FRONT PILLAR GARNISH

- Pry out two clips by your hand.
- Pull the garnish upward to remove it.

2. REMOVE WINDSHIELD MOULDING

(See page BO-20)

3. REMOVE FOLLOWING PARTS:

Hood, wiper arms and cowl louver

4. (Molded Coiling Type)

REMOVE FRONT SIDE OF ROOF HEADLINING

(w/ moon roof)

See steps 2 to 4 on page B0-42.

(w/o moon roof)

(a) Remove following parts:

- Inner rear view mirror, sun visors, holders and assist grips.

(b) Remove the personal light cover.

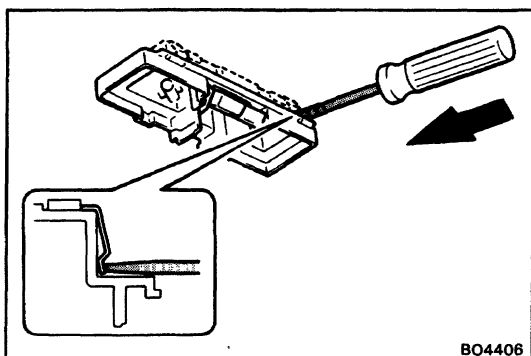

BO4406

- (c) Remove the personal light switch base by hand while pressing the clips down with a screwdriver.

HINT: Tape the screwdriver tip before use.

- (d) Remove opening trim moulding and assist grips.
 (e) Pull down the headlining by hand.

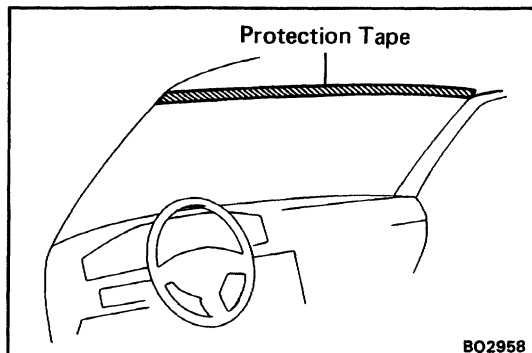

BO2958

5. (Suspended Ceiling Type)

APPLY PROTECTION TAPE TO FRONT SIDE OF ROOF HEADLINING

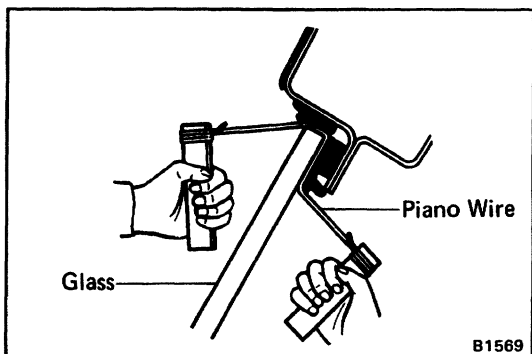

B1569

6. REMOVE WINDSHIELD GLASS

NOTICE: When separating, take care not to damage the wire.

- (a) Push piano wire through from the interior.
 (b) Tie both wire ends to a wooden block or like object.
 HINT: Apply adhesive tape to the outer surface to keep the surface from being scratched.

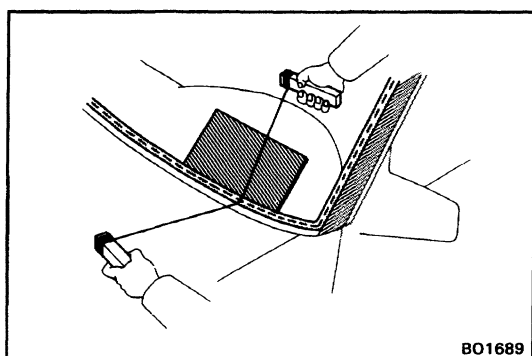

BO1689

NOTICE: When separating, take care not to damage the paint and interior and exterior ornaments. To prevent scratching the safety pad when removing the windshield, place a plastic sheet between the piano wire and safety pad.

- (c) Cut the adhesive by pulling the piano wire around it.
 (d) Remove the glass.

NOTICE: Leave as much of the adhesive on the body as possible when cutting off the glass.

PREPARATION FOR INSTALLATION

1. CLEAN AND SHAPE CONTACT SURFACE OF BODY

- (a) Remove any dam remaining on the body.
 (b) Cut away any rough areas with a knife.
 HINT: Leave as much of the adhesive on the body as possible.
 (c) Clean the cutting surface of the adhesive with a piece of cloth saturated in cleaner.

HINT: Even if all the adhesive has been removed, clean the body.

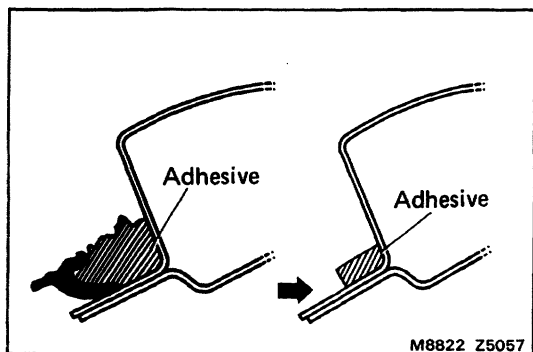

M8822 Z5057

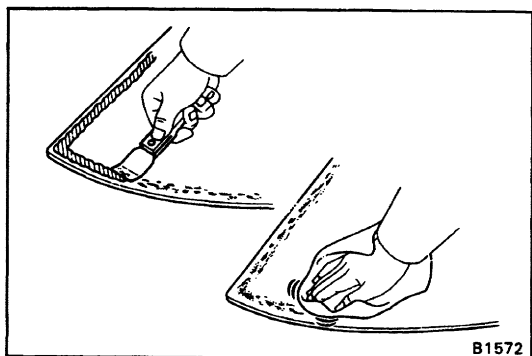

2. IF NECESSARY, REPLACE FASTENERS

(See page [BO-21](#))

3. CLEAN REMOVED GLASS BEFORE INSTALLATION

- Using a scraper, remove the adhesive sticking to the glass.
- Clean the glass with cleaner.

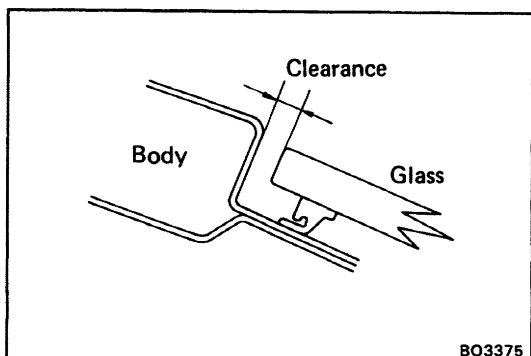

4. SELECT RETAINERS

HINT: If replacing the retainer, select the retainer by the following method.

- Install the old type retainer or any type retainer.
- Place the windshield glass to the body.
- Measure the clearance between the top of the windshield glass and body as shown.

Standard clearance: 7.7 mm (0.303 in.)

If the clearance is not as specified, replace the retainer with one of the correct size.

5. INSTALL RETAINERS

If replacing the retainer, remove backing paper from new retainer and apply it to cut portion at lower side of the windshield glass.

HINT: Before install the retainer, coat the cut portion of glass with Primer G.

(See step 4 on page [BO-33](#))

6. INSTALL SPACER

If replacing the spacer, remove backing paper from new spacer and apply it to cut portion at center of lower side of the windshield glass.

HINT: Before install the spacer, coat the cut portion of glass with Primer G.

(See step 4 on page [BO-33](#))

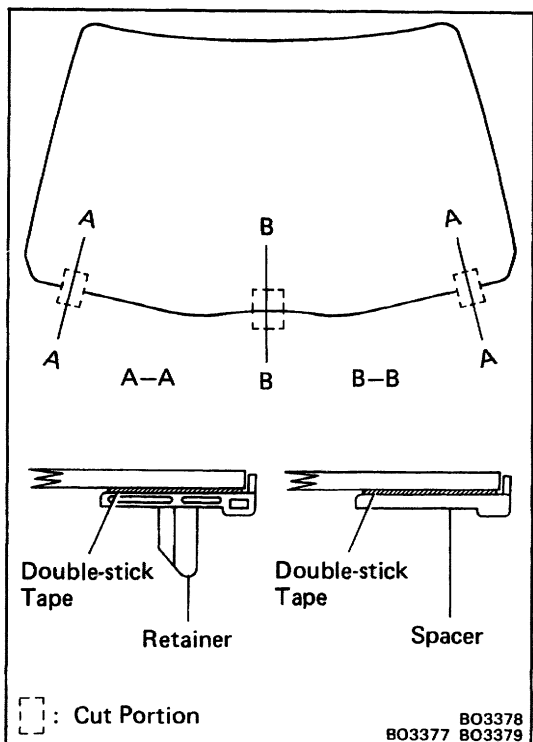

7. POSITION GLASS

- Place glass in correct position.
- Check that all contacting parts of the glass rim are perfectly even and do not make contact with the fasteners.
- Mark reference marks between the glass and body.
- Remove the glass.

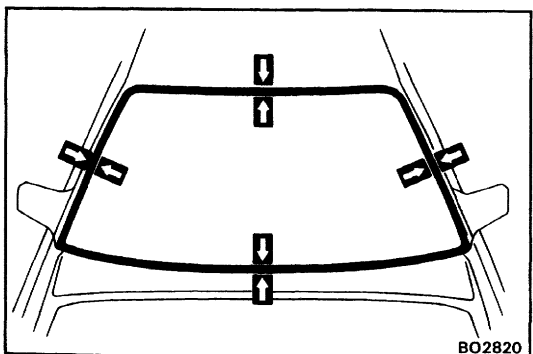

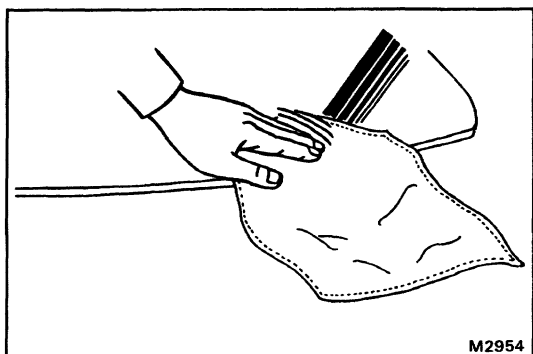

INSTALLATION OF WINDSHIELD

(See page BO-30)

1. CLEAN CONTACT SURFACE OF GLASS

Using a cleaner, clean the contact surface black-colored area around the entire glass rim.

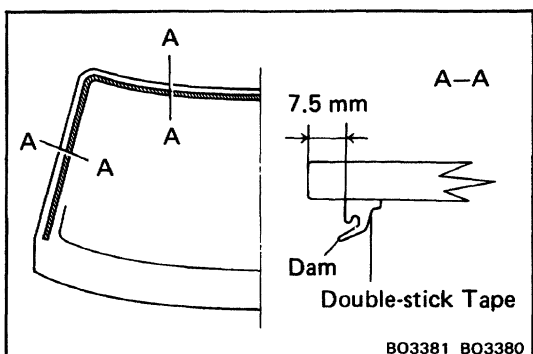

2. INSTALL DAM

- Apply double-stick tape at a point 7.5 mm (0.295 in.) from the glass rim as shown in the illustration.
- Place the dam on the double-stick tape.

NOTICE: Do not touch the glass face after cleaning it.

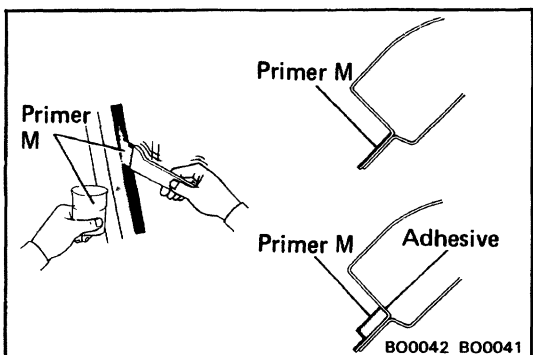

3. COAT CONTACT SURFACE OF BODY WITH PRIMER "M"

Using a brush, coat the contact surface on the body with Primer M.

NOTICE:

- Let the Primer coating dry for 10 minutes or more. Make sure that the installation of the glass is finished within 2 hours.
- Use care not to leave any part of the contact surface uncoated or excessively coated, as Primer M and G serve to boost the adhesive power of the adhesive to the glass or body.
- Do not keep any of the opened Primer M and G for later use.

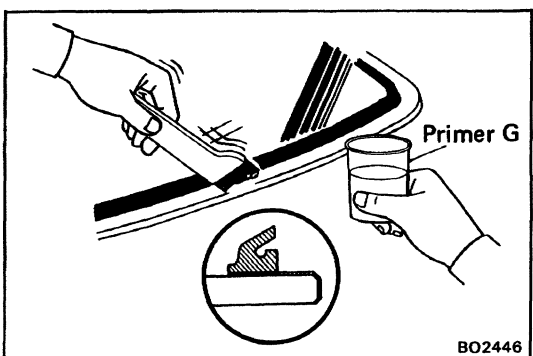

4. COAT CONTACT SURFACE OF GLASS WITH PRIMER "G"

- Using a brush or sponge, coat the edge of the glass and the contact surface with Primer G.
- Before the Primer dries, wipe any excess off with a clean cloth to avoid too thick a coat.

NOTICE: Be sure that installation of the glass is finished within 70 minutes.

5. MIX ADHESIVE COATING

NOTICE:

- Be sure that installation of the glass is finished within usable time. (See step 2 on page BO-29)
 - The mixture should be made in 5 minutes or less.
- Thoroughly clean the glass plate and putty spatula with solvent.
 - Thoroughly mix 500 g (17.64 oz.) of the main agent and 75 g (2.65 oz.) of the hardening agent on a glass plate or like object with a putty spatula.

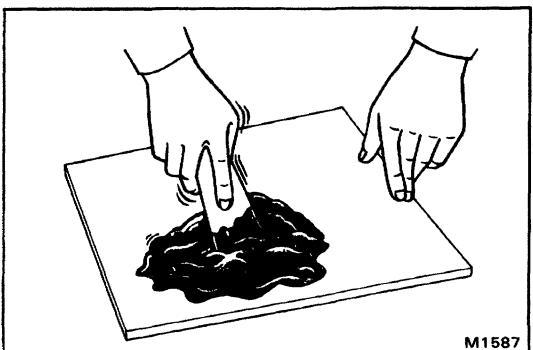

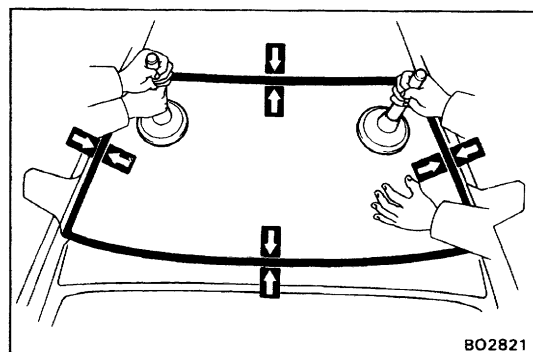
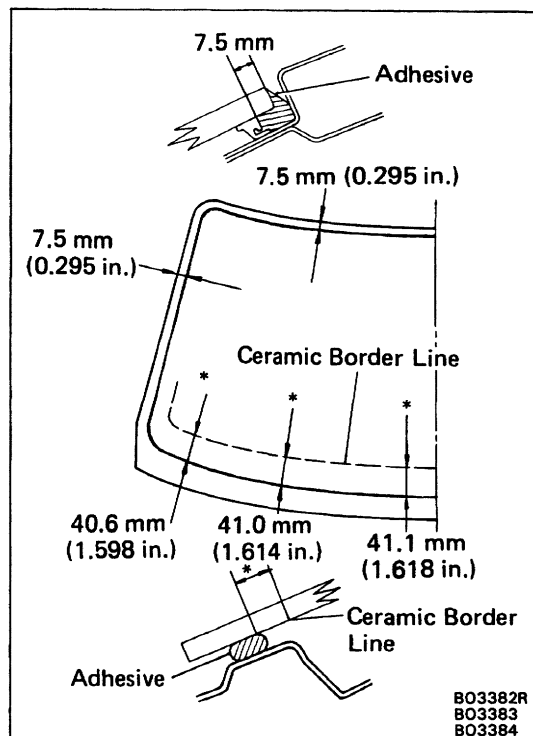

6. APPLY ADHESIVE

- Cut off the tip of the cartridge nozzle to make a hole 5 mm (0.20 in.) in diameter. Fill the cartridge with adhesive.
- Load the cartridge into the sealer gun.
- Coat the glass with adhesive on all contact surfaces along the ridge.

Adhesive height: If adhesive remains on body

3.5 – 5.0 mm (0.138 – 0.197 in.)

If no adhesive remains on body

8 – 10 mm (0.31 – 0.39 in.)

- Apply adhesive on the location as shown.

7. INSTALL GLASS

- Position the glass so that the reference marks are lined up, and press in gently along the rim.
- Using a spatula, apply adhesive on the glass rim.
- Use a spatula to remove any excess or protruding adhesive.
- Fasten glass securely until the adhesive sets.

8. INSPECT FOR LEAKS AND REPAIR

- Perform a leak test after the hardening time has elapsed.
- Seal any leak with auto glass sealer.

Part No. 08833-00030 or equivalent

9. INSTALL WINDSHIELD MOULDING

(See page [BO-21](#))

10. INSTALL FOLLOWING PARTS:

- [USA and CANADA (w/ Moon roof)]
Front side of roof headlining
- Control switch base and control switch cover
- Inner rear view mirror, sun visors and holders
- Front pillar garnishes, cowl louver and wiper arms

11. INSTALL AND ADJUST HOOD

(See page [BO-3](#))

NOTICE: Wait at least twice the setting time before driving the car.