

MOULDING

Windshield Moulding

COMPONENTS

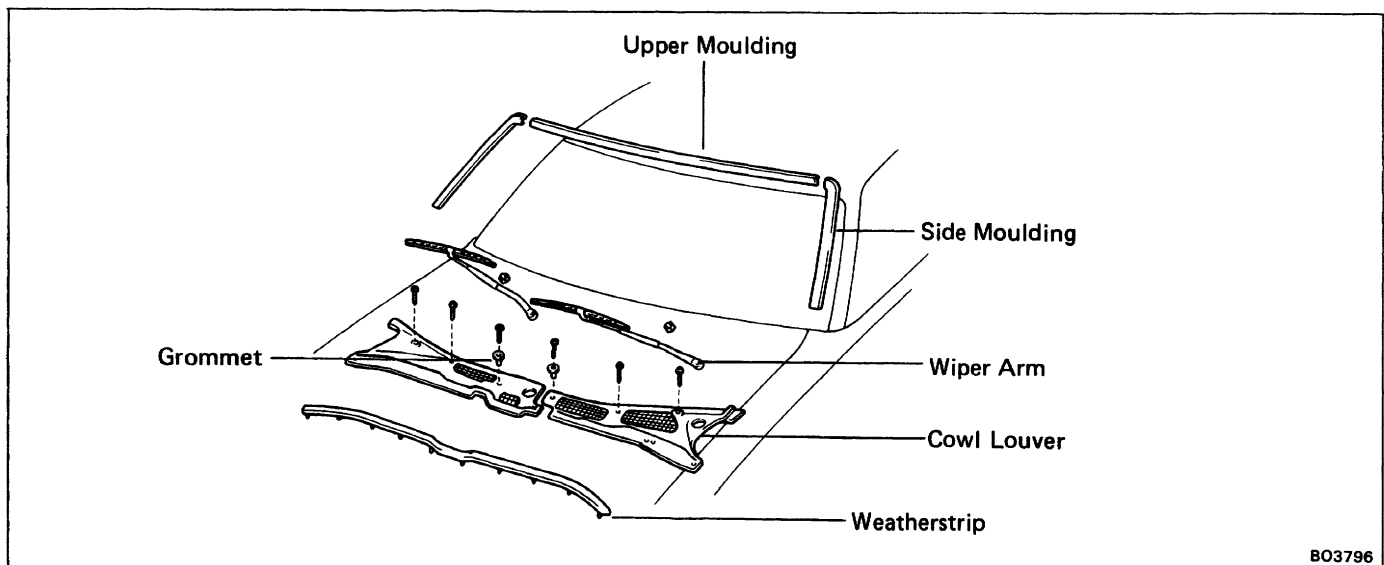

B03796

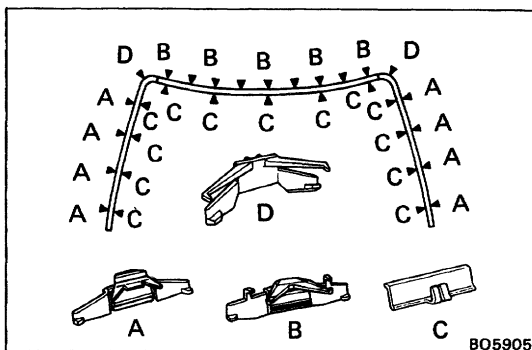

REMOVAL OF WINDSHIELD MOULDING

Locations of clips (A and B) and fasteners (C) are as shown. Carefully apply adhesive tape to protect the body.

1. REMOVE WIPER ARM

2. REMOVE COWL LOUVER

- (a) Using a clip remover, pry out ten clips with the weatherstrip.
- (b) Remove six screws.
- (c) Using a screwdriver, pry up two grommets.
HINT: Tape the screwdriver tip before use.
- (d) Remove the cowl louver.

3. REMOVE SIDE MOULDING

- (a) Install the top of a scraper between the body and moulding.

HINT: Tape the scraper tip before use to prevent scratching the vehicle body.

- (b) Pry up the scraper to loosen the moulding from the claws of the clips and fasteners.
- (c) Remove the moulding.

4. REMOVE UPPER MOULDING

Remove the upper moulding in the same manner as the side moulding.

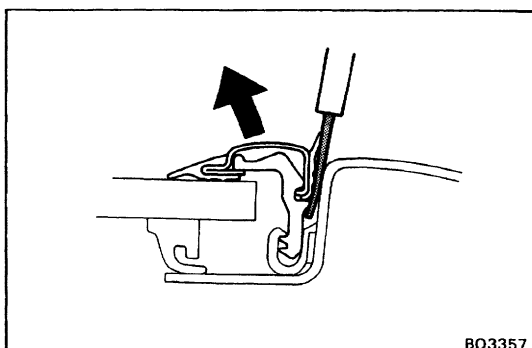
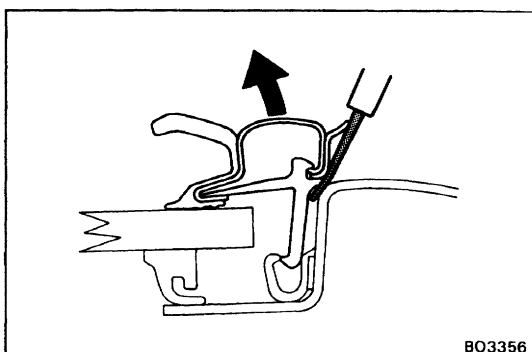

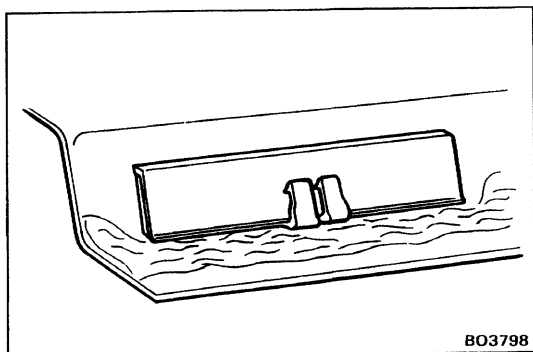

REPLACEMENT OF FASTENER

REPLACE FASTENER

- (a) Remove the damaged fastener.
- (b) Cut off the old adhesive around the fastener installation area.

HINT: Be careful not to damage the body.

- (c) Clean the installation area.
- (d) Install a new fastener onto the body.

INSTALLATION OF WINDSHIELD MOULDING

1. INSTALL NEW CLIP INTO MOULDING

Install the clip to the appropriate place on the moulding, where the clip would engage with the fastener.

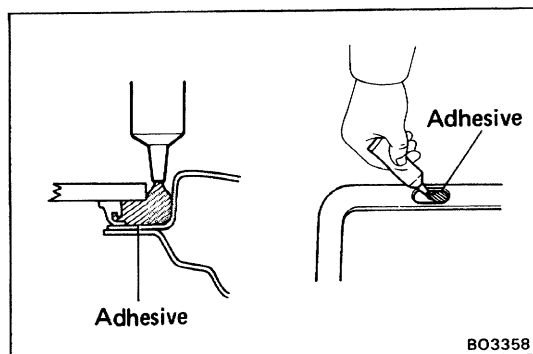

2. APPLY ADHESIVE AT NEW CLIP INSTALLATION AREA

- (a) When the clip being engaged with the moulding is removed, cut out the old adhesive around the clip installation area.

NOTICE: Do not damage the body and fastener.

- (b) Apply adhesive at the clip installation area so water does not collect there.

3. INSTALL UPPER MOULDING

- (a) Place the moulding onto the body.
- (b) Tap the moulding with your hand to fasten the clips at the glass edge.
At the same time, install the fastener, by tapping them by hand.

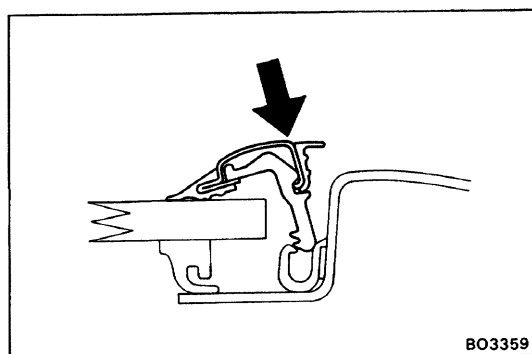

4. INSTALL SIDE MOULDING

Install the side moulding in the same manner as the upper moulding.

5. INSTALL COWL LOUVER

Push ten clips into retainers and install the louver with two grommets and six screws.

6. INSTALL WIPER ARM

