

# SHIFT LOCK SYSTEM COMPONENT AND CIRCUIT

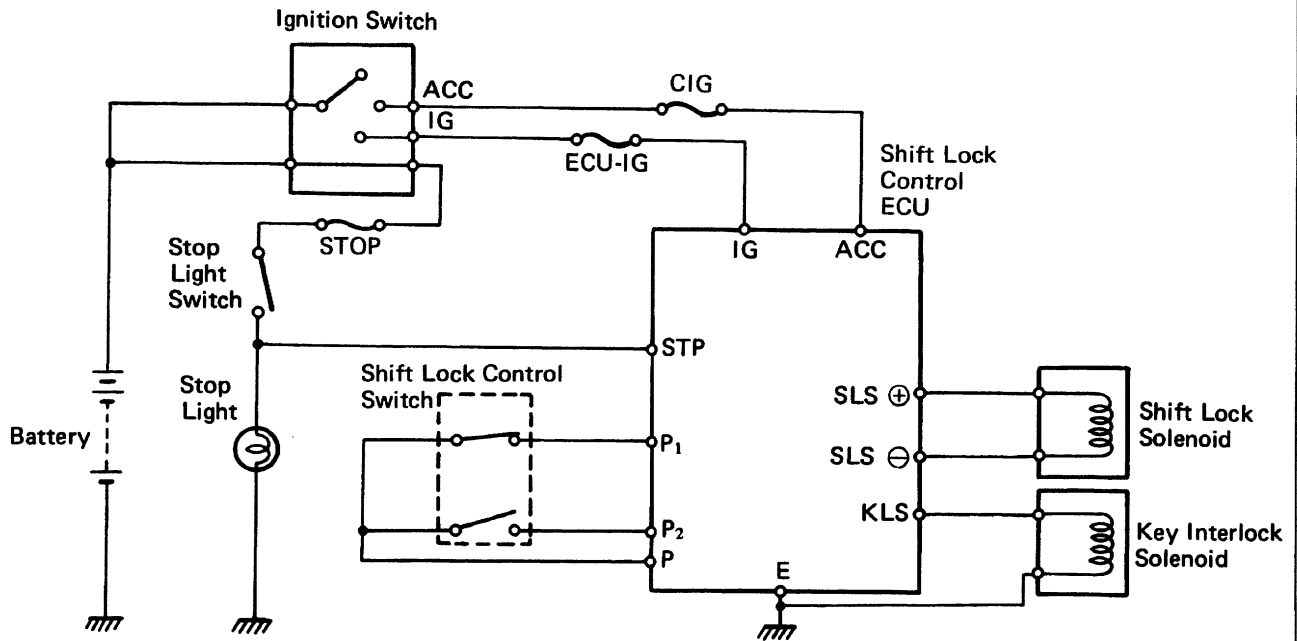

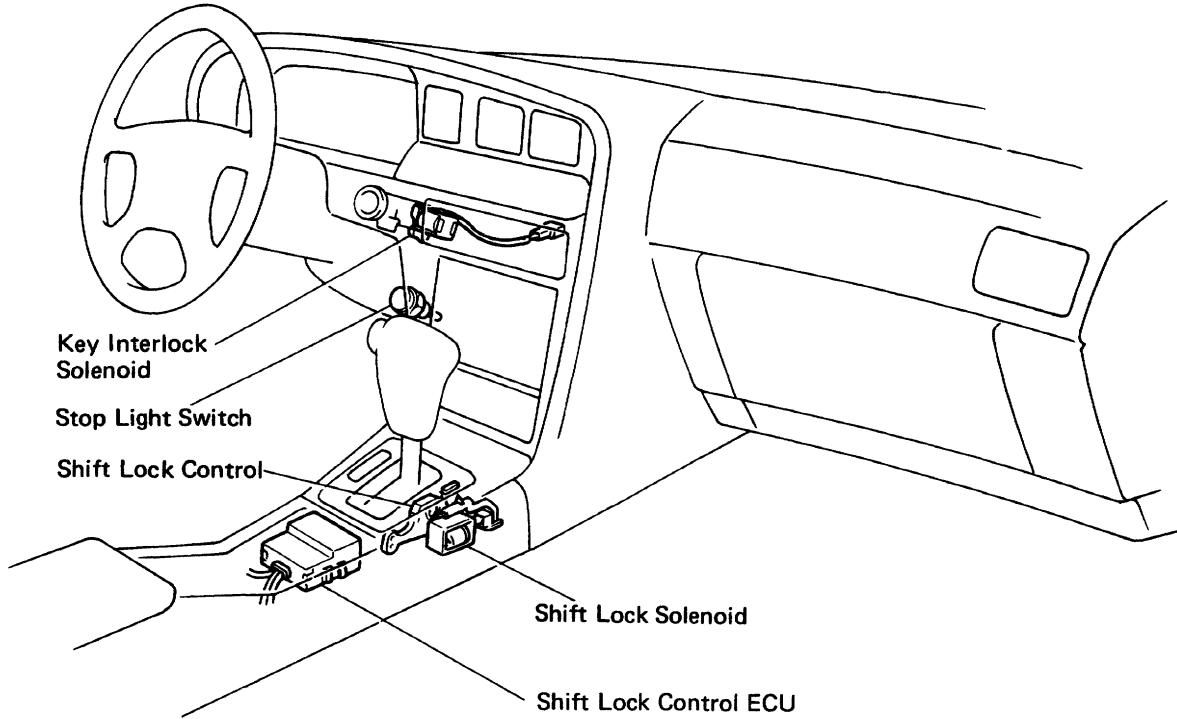
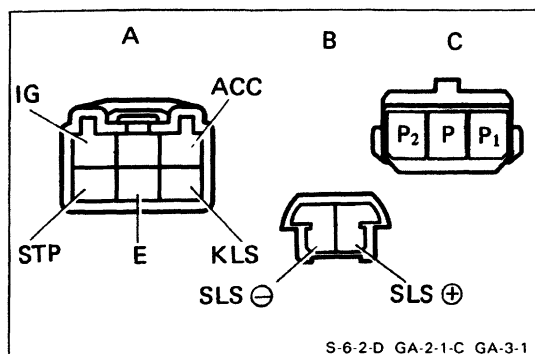

## INSPECTION OF ELECTRIC CONTROL COMPONENTS

### 1. INSPECT SHIFT LOCK CONTROL ECU

Using a voltmeter, measure the voltage at each terminals.

Connector	Terminal	Measuring condition	Voltage (V)	
A	ACC – E	IG SW ACC position	10 – 14	
	IG – E	IG SW ON position	10 – 14	
	STP – E	Depress brake pedal	10 – 14	
	KLS – E	①	IG SW ACC position and P range	0
②		R, N, D, 2, L ranges	10 – 14	
③		(after one second)	6 – 9	
B	SLS ⊕ – SLS ⊖	①	IG SW ON position and P range	0
		②	Depress brake pedal	8.5 – 13.5
		③	(after 20 seconds)	5.5 – 9.5
		④	R, N, D, 2, L ranges	0
C	P₁ – P	①	IG SW ON, P range and depress brake pedal	0
		②	R, N, D, 2, L ranges	9 – 13.5
	P₂ – P	①	IG SW ACC position and P range	9 – 13.5
		②	R, N, D, 2, L ranges	0

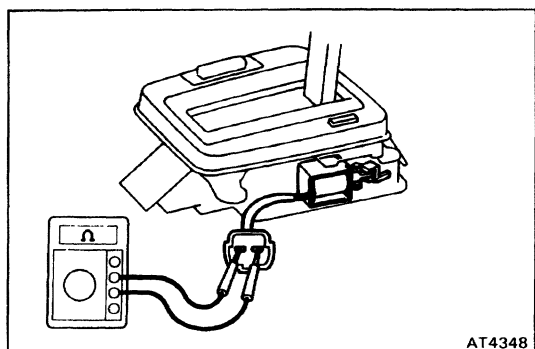

### 2. INSPECT SHIFT LOCK SOLENOID

- (a) Disconnect the solenoid connector.
- (b) Using an ohmmeter, measure the resistance between terminals.

**Standard resistance: 20 – 28 Ω**

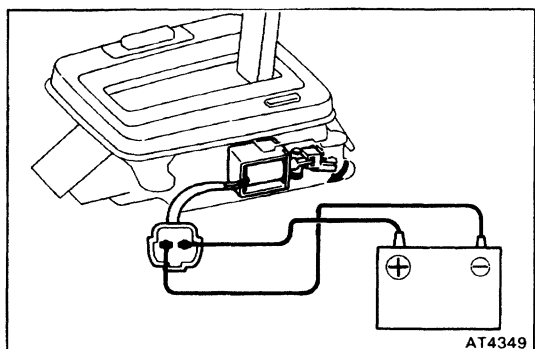

- (c) Apply the battery voltage between terminals.  
At this time, confirm that a solenoid operation.

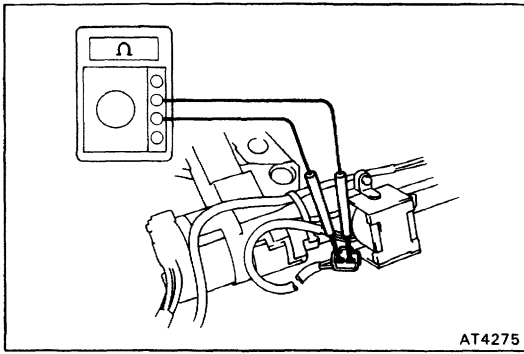

**3. INSPECT KEY INTERLOCK SOLENOID**

- (a) Disconnect the solenoid connector.
- (b) Using an ohmmeter, measure the resistance between terminals.

**Standard resistance: 12 – 17 Ω**

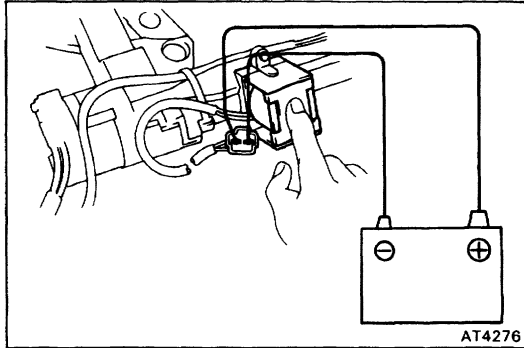

- (c) Apply the battery voltage between terminals.  
At this time, confirm that a solenoid operation.

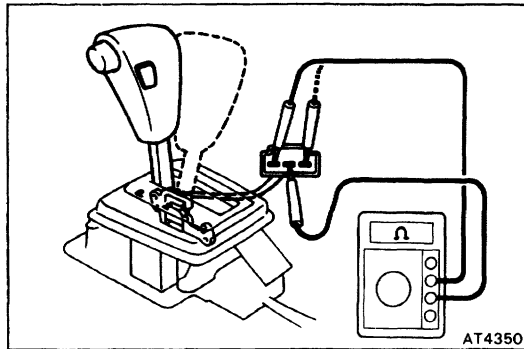

**4. INSPECT SHIFT LOCK CONTROL SWITCH**

Inspect that there is continuity between each terminals.

○—○: Continuity

Terminal	P	P <sub>1</sub>	P <sub>2</sub>
Shift Position			
P range (Release button is not pushed)	○—○		
R, N, D, 2, L ranges	○—○	○—○	