

# Electronic Control System

## PRECAUTION

Do not open the cover to the case or the Engine & ECT ECU and various computer unless absolutely necessary. (If the IC terminals are touched, the IC may be destroyed by static electricity.)

## ELECTRONIC CONTROL CIRCUIT

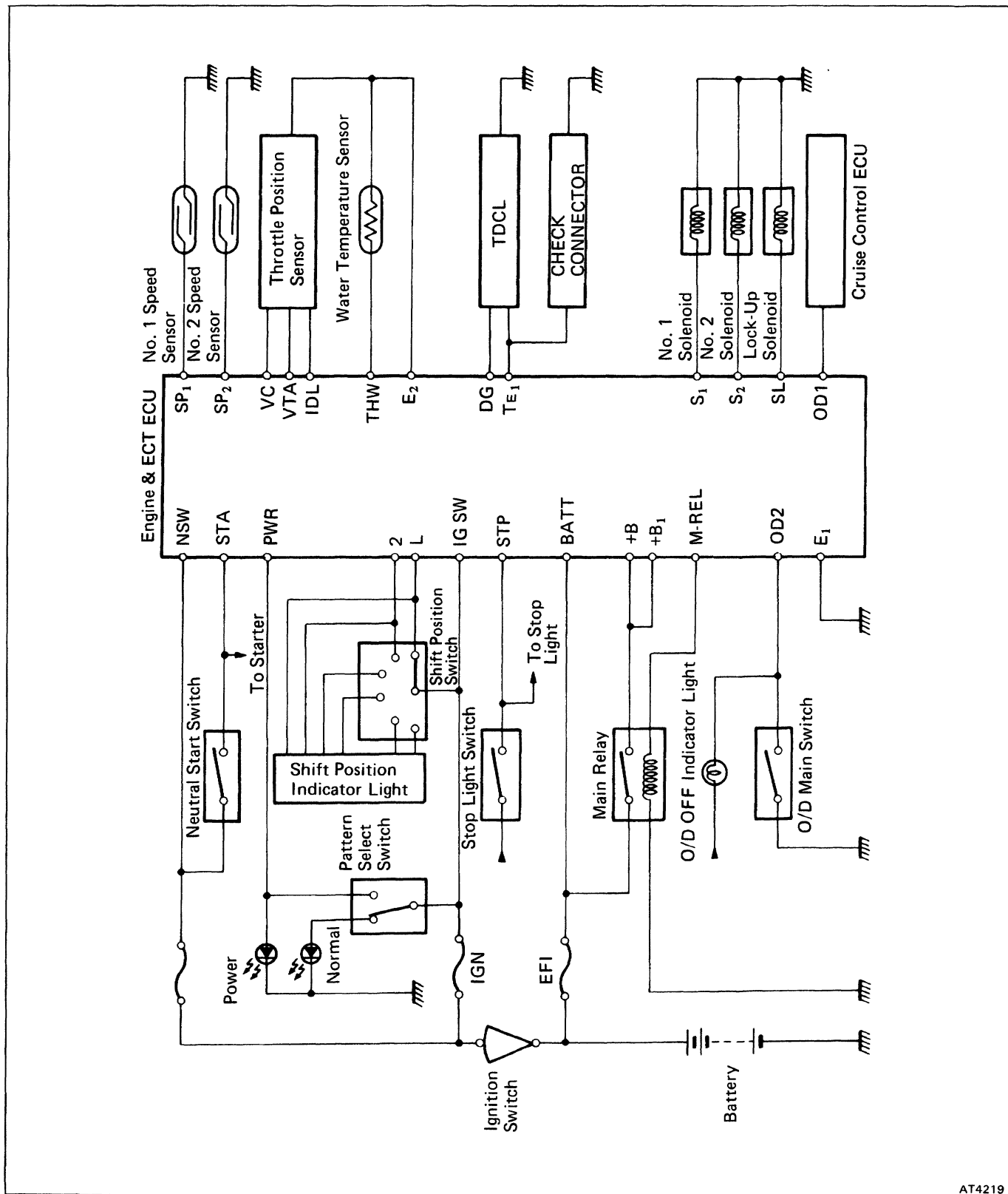

# ELECTRONIC CONTROL COMPONENTS

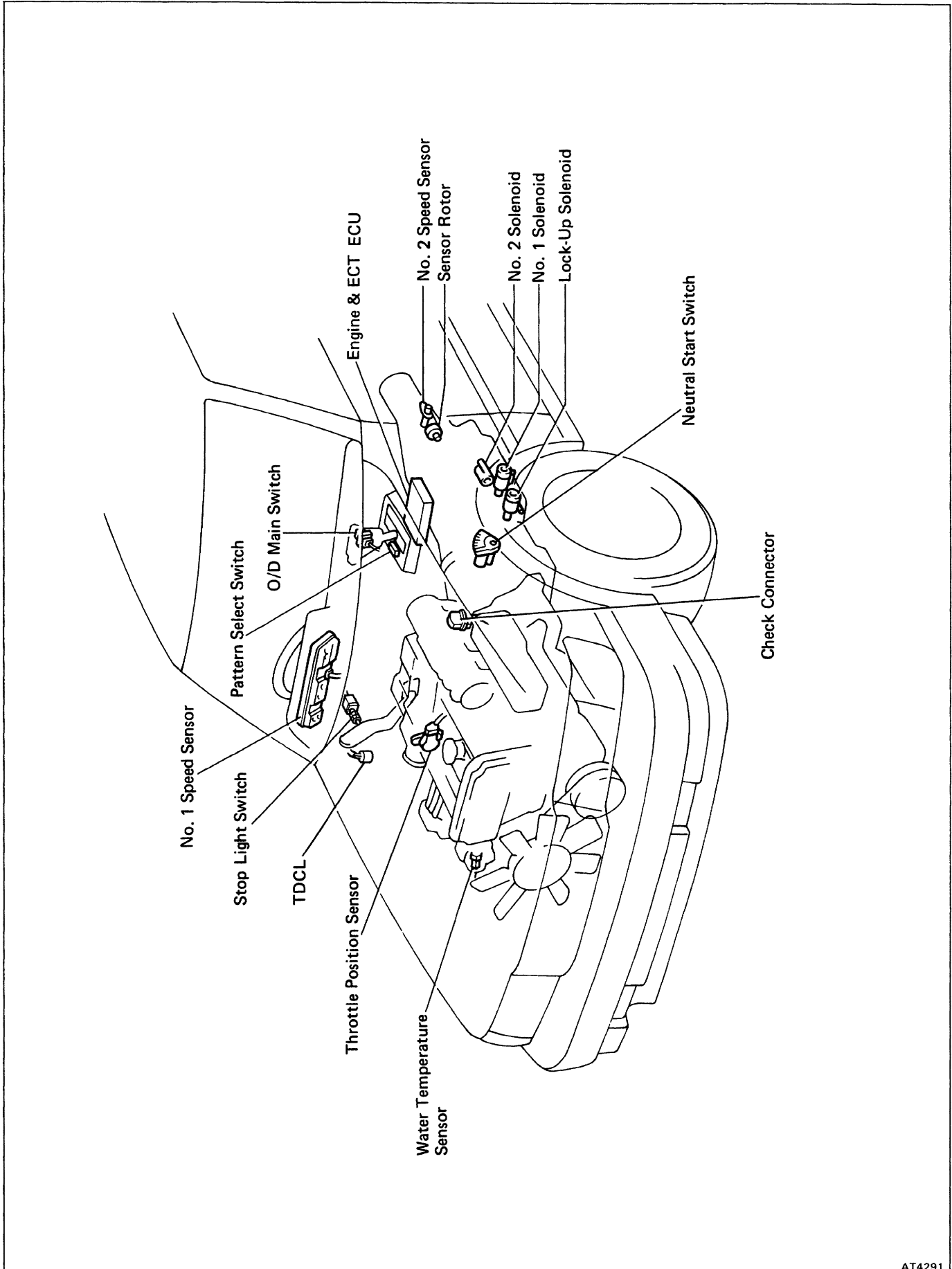

# TROUBLESHOOTING FLOW-CHART

## Trouble No. 1 No Shifting

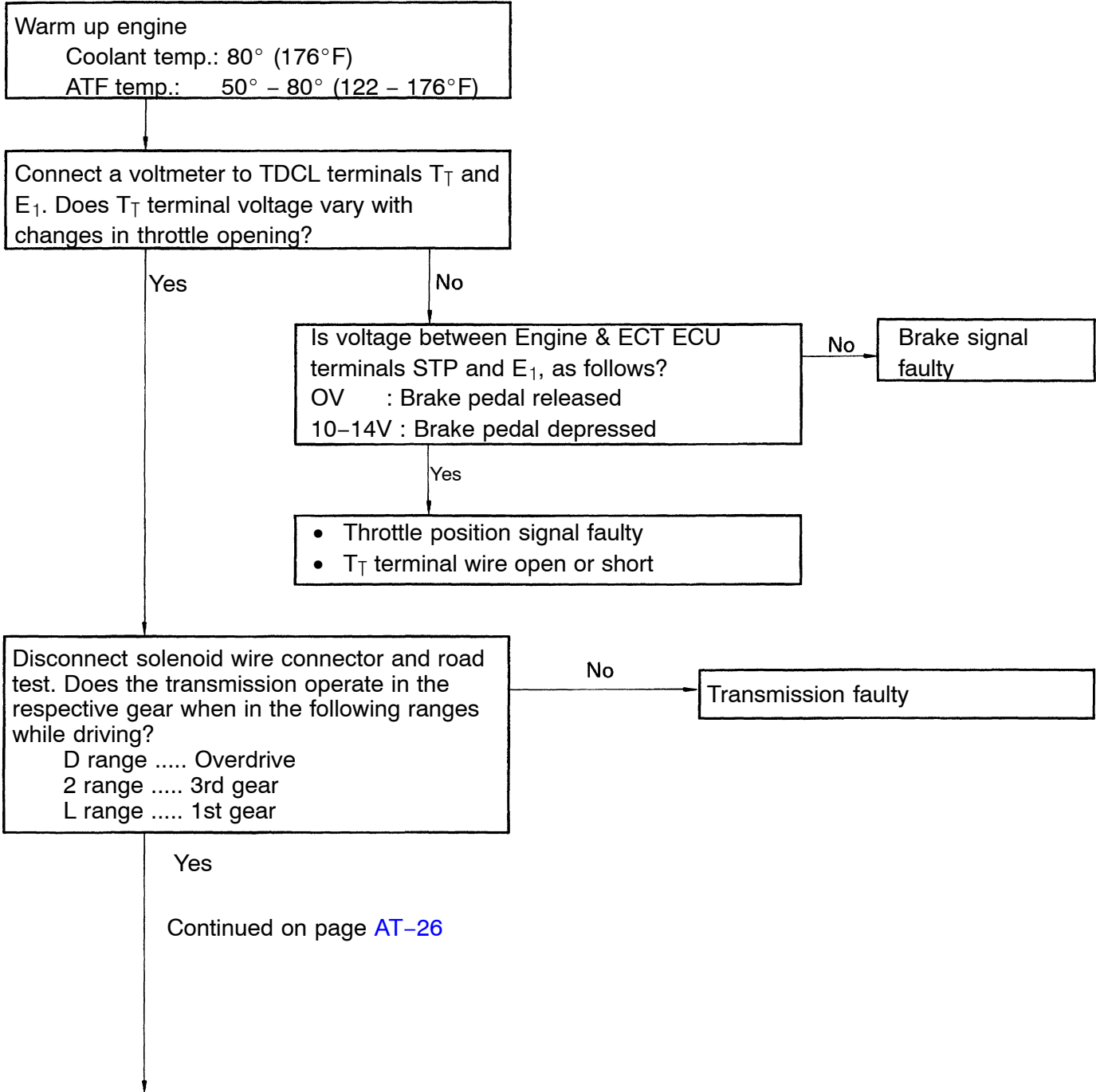

Continued from page AT-25

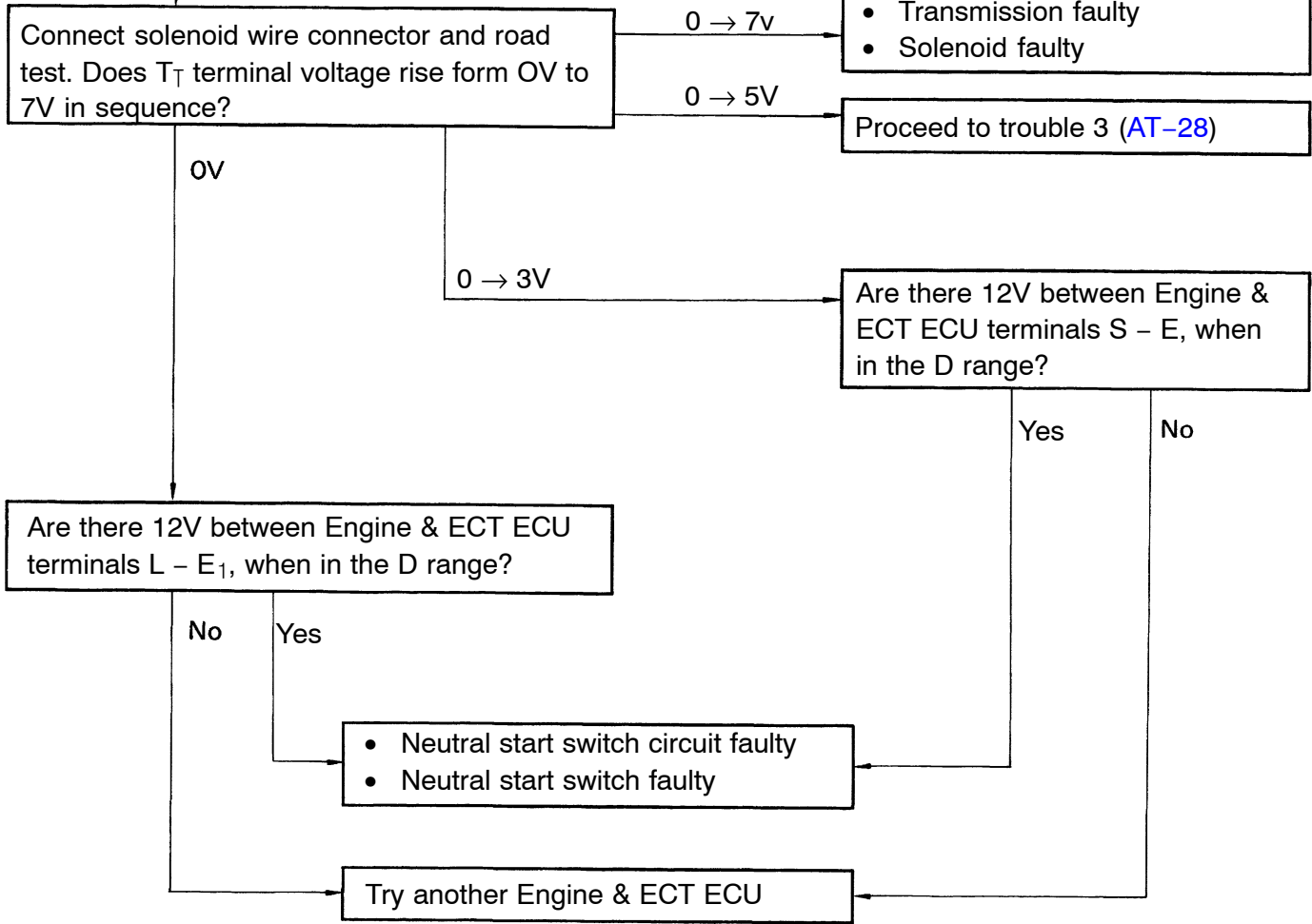

**Trouble No-2 Shift point too high or too low**

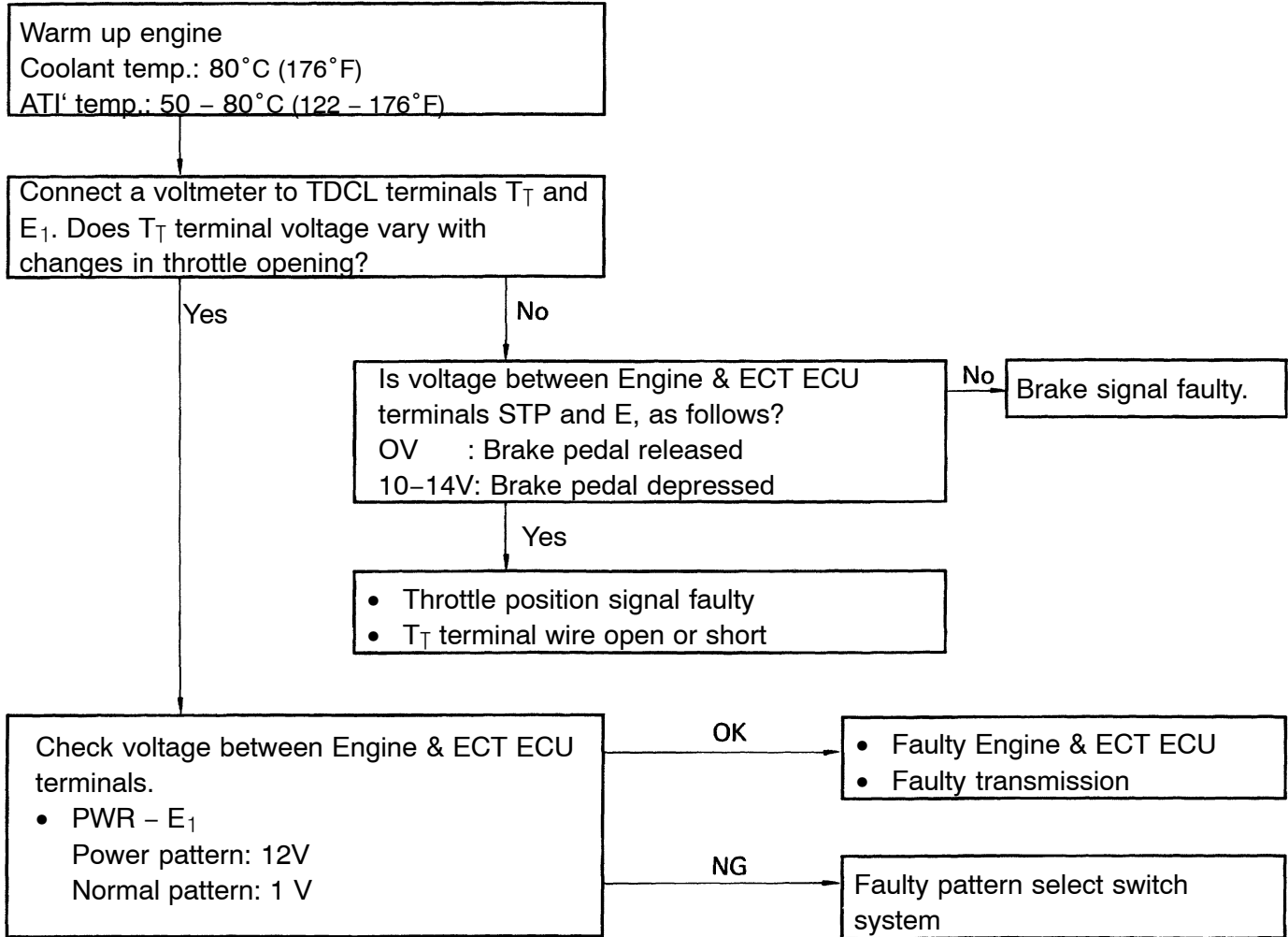

**Trouble No.3 No up-shift to overdrive (After warm-up)**

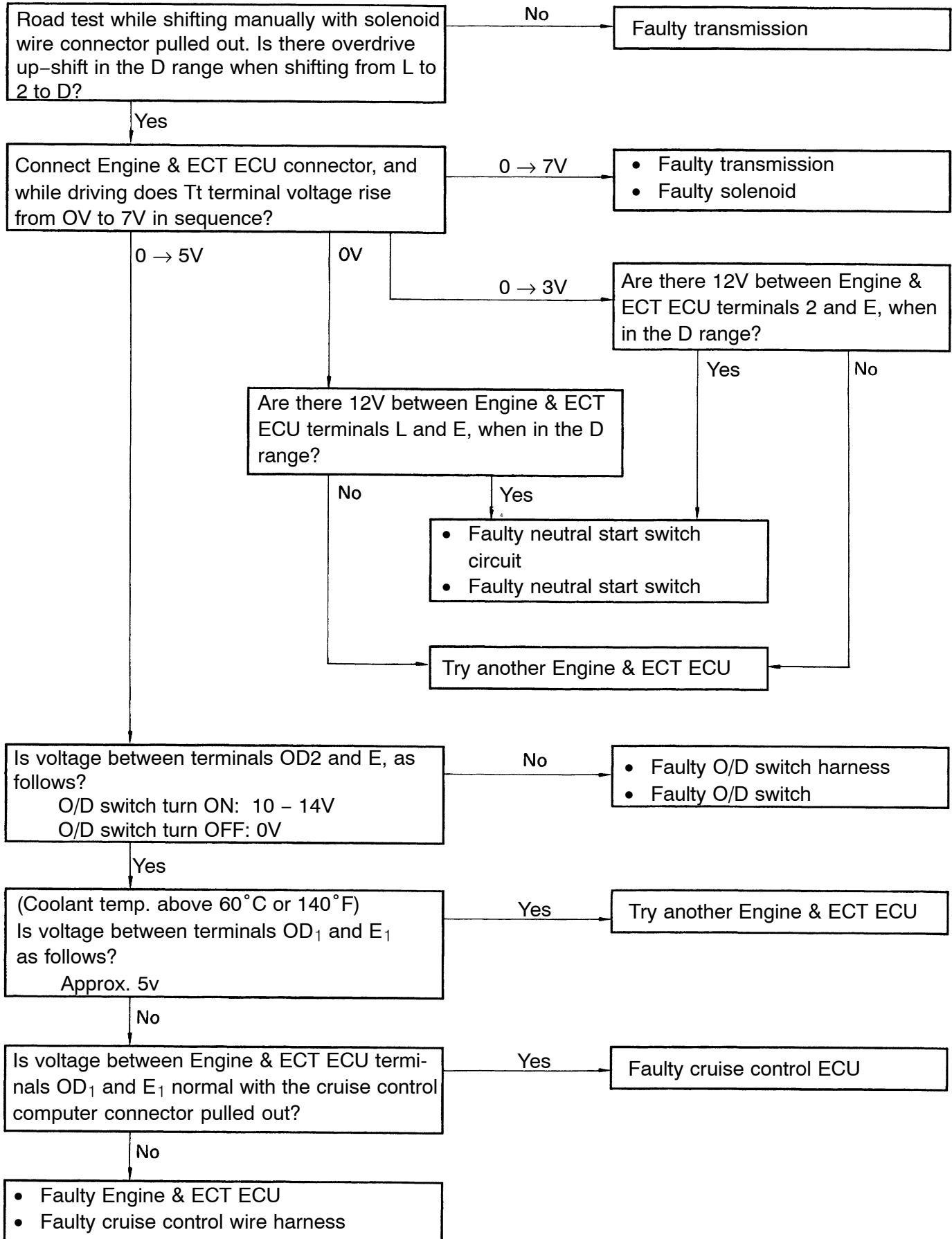

**Trouble No.4 No lock-up (After warm-up)**

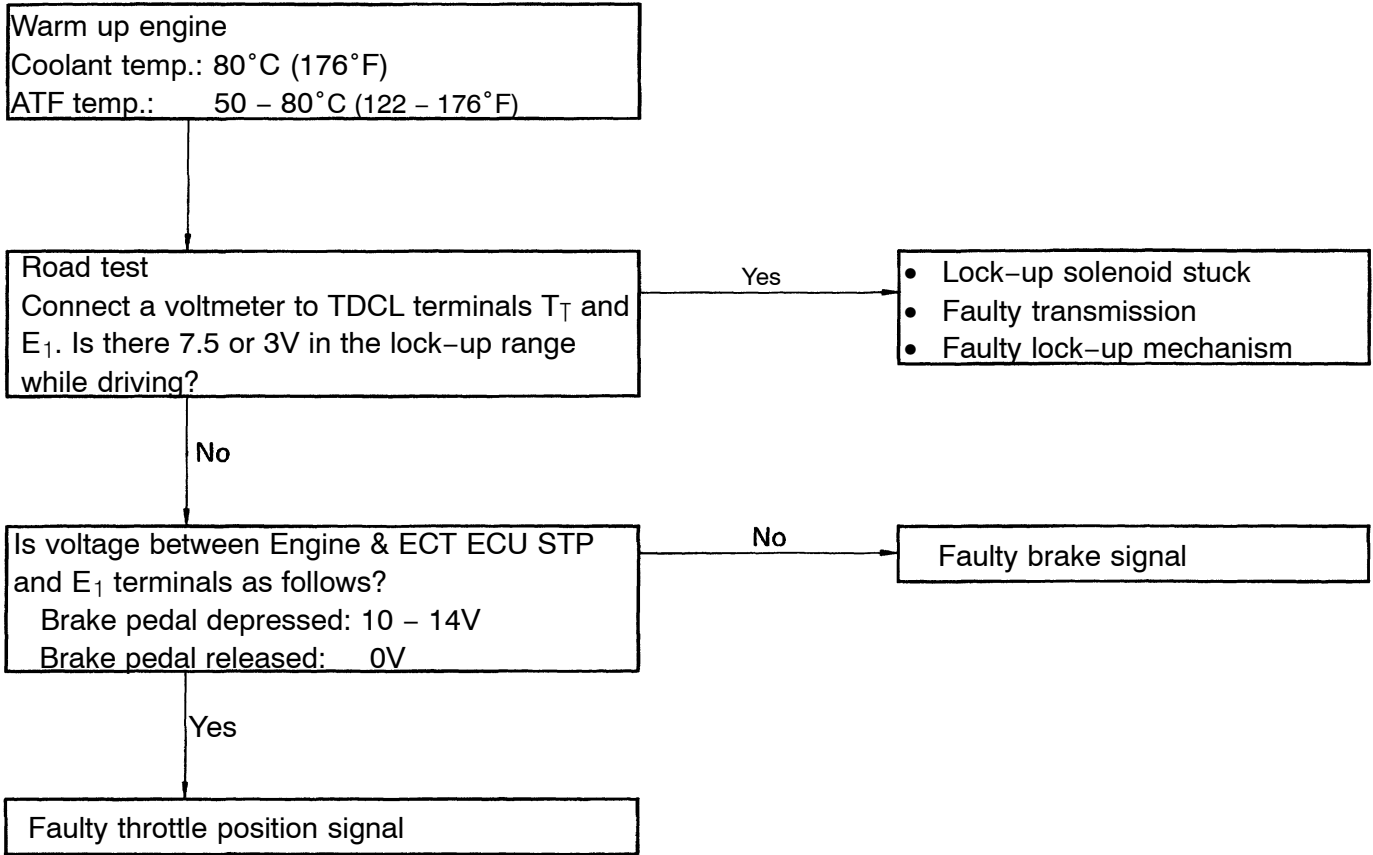

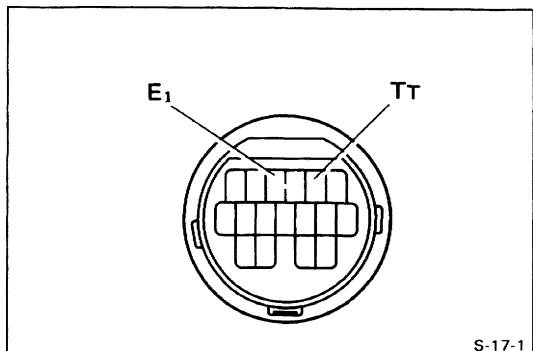

S-17-1

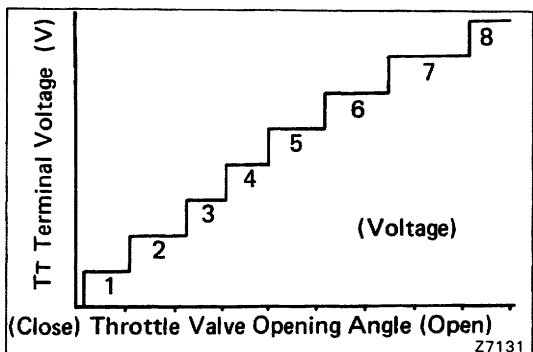

Z7131

## INSPECTION OF T<sub>T</sub> TERMINAL VOLTAGE

### 1. INSPECT THROTTLE POSITION SENSOR SIGNAL

- (a) Turn the ignition switch to ON. Do not start the engine.
- (b) Connect a voltmeter to TDCL terminals T<sub>T</sub> and E<sub>1</sub>.

(c) While slowly depressing the accelerator pedal, check that T<sub>T</sub> terminal voltage rises in sequence. If the voltage does not change in proportion to the throttle opening angle, there is a malfunction in the throttle position sensor or circuit.

### 2. INSPECT BRAKE SIGNAL

- (a) Depress the accelerator pedal until the T<sub>T</sub> terminal indicates 8V.
- (b) Depress the brake pedal and check the voltage reading from the T<sub>T</sub> terminal.
  - Brake pedal depressed ..... 0V
  - Brake pedal released ..... 8V

If not as indicated, there is a malfunction in either the stop light switch or circuit.

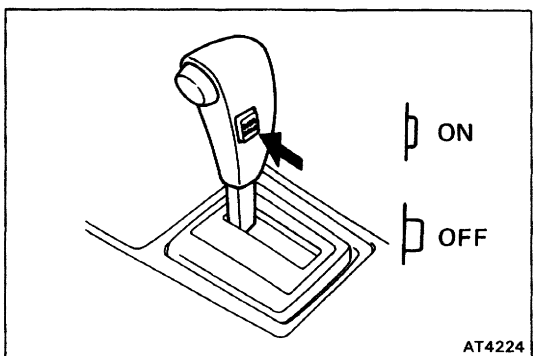

AT4224

### 3. INSPECT EACH UP-SHIFT POSITION

- (a) Warm up the engine.
  - Coolant temperature: 80°C (176°F)**
- (b) Turn the O/D switch to "ON".
- (c) Place the pattern select switch in "Normal" and the shift lever into the D range.
- (d) During a road test (above 10 km/h or 6 mph) check that voltage at the T<sub>T</sub> terminal is as indicated below for each up-shift position.

If the voltage rises from 0V to 7V in the sequence shown, the control system is okay.

The chart on the left shows the voltmeter reading and corresponding gears.

HINT: Determine the gear position by a light shock or change in engine rpm when shifting. The lock-up clutch will turn ON only infrequently during normal 2nd and 3rd gear operation. To trigger this action, press the accelerator pedal to 50% or more of its stroke. At less than 50%, the voltage may change in the sequence 2V - 4V - 6V - 7V.

T <sub>T</sub> Terminal (V)	Gear Position
0	1st
2	2nd
3	2nd Lock-up
4	3rd
5	3rd Lock-up
6	O/D
7	O/D Lock-up

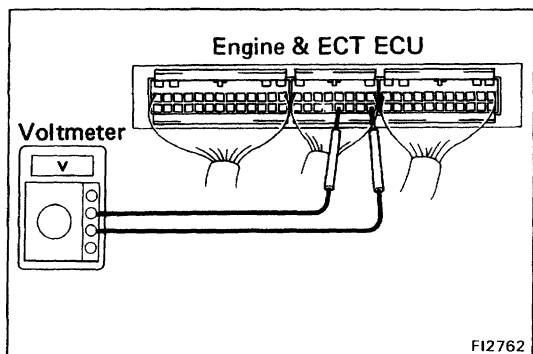

# INSPECTION OF ELECTRONIC CONTROL COMPONENTS

## 1. INSPECT VOLTAGE OF Engine & ECT ECU CONNECTOR

- (a) Turn on the ignition switch.
- (b) Measure the voltage at each terminal.

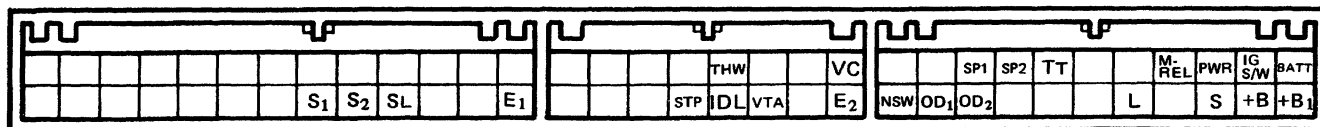

F12796

Terminal	Measuring condition	Voltage (V)	
S <sub>1</sub> - E <sub>1</sub>	—	10 - 14	
S <sub>2</sub> , S <sub>L</sub> - E <sub>1</sub>	—	0	
PWR - E <sub>1</sub>	PWR pattern	10 - 14	
	NORM pattern	0 - 2	
STD - E <sub>1</sub>	Brake pedal is depressed	10 - 14	
	Brake pedal is released	0	
THW - E <sub>2</sub>	Coolant temp. 80°C (176°F)	0.1 - 1.0	
IDL - E <sub>2</sub>	Throttle valve fully closed	0	
	Throttle valve open	10 - 14	
VTA - E <sub>2</sub>	Throttle valve fully closed	0.1 - 1.0	
	Throttle valve fully open	4 - 5	
VC - E <sub>2</sub>	—	4 - 6	
OD <sub>1</sub> - E <sub>1</sub>	—	5	
OD <sub>2</sub> - E <sub>1</sub>	O/D main switch turned ON	10 - 14	
	O/D main switch turned OFF	0	
SP <sub>1</sub> - E <sub>1</sub>	Cruise control main switch OFF	Standing still	0 or 5
		Vehicle moving	2 - 3
SP <sub>2</sub> - E <sub>1</sub>	Standing still	0 or 5	
	Vehicle moving	2 - 3	

Terminal	Measuring condition	Voltage (V)
N - E <sub>1</sub>	N range	10 - 14
	Except N range	0 - 2
2 - E <sub>1</sub>	2 range	10 - 14
	Except 2 range	0 - 2
L - E <sub>1</sub>	L range	10 - 14
	Except L range	0 - 2
IG S/W - E <sub>1</sub> M-REL - E <sub>1</sub> +B - E <sub>1</sub> +B <sub>1</sub> - E <sub>1</sub>	-	10 - 14
BATT - E <sub>1</sub>	-	10 - 14

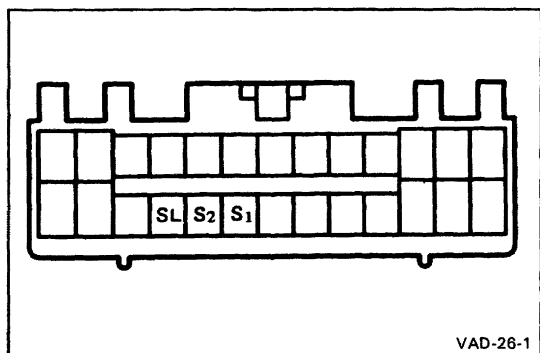

## 2. INSPECT SOLENOIDS

- Disconnect the connector from Engine & ECT ECU.
- Measure the resistance between S<sub>1</sub>, S<sub>2</sub>, SL and body ground.

**Resistance: 11 - 15Ω**

- Apply battery voltage to each terminal.  
Check that an operation noise can be heard from the solenoid.

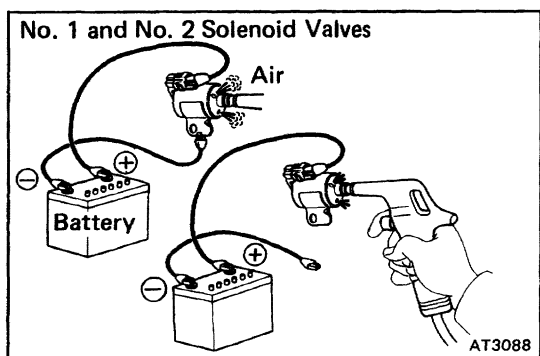

## 3. CHECK SOLENOID SEALS

If there is foreign material in the solenoid valve, there will be no fluid control even with solenoid operation.

- Check No. 1 and No. 2 solenoid valves.
  - Check that the solenoid valves do not leak when low-pressure compressed air is applied.
  - When supply battery voltage to the solenoids, check that the solenoid valves open.
- Check the lock-up solenoid valve.
  - Applying 5 kg/cm<sup>2</sup> (71 psi, 490 kPa) of compressed air, check that the solenoid valve opens.
  - When supply battery voltage to the solenoid, check that the solenoid valve does not leak the air.

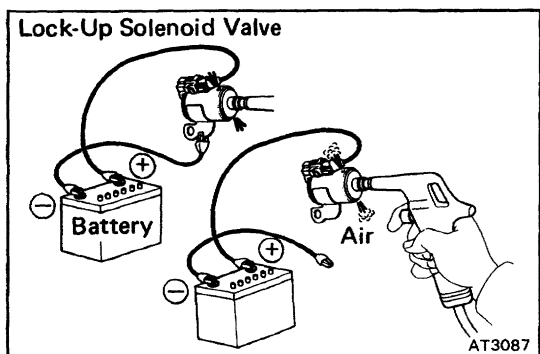

If a malfunction is found during voltage inspection (step 1.), inspect the components listed below.

## 4. INSPECT NEUTRAL START SWITCH

(See page AT-42)

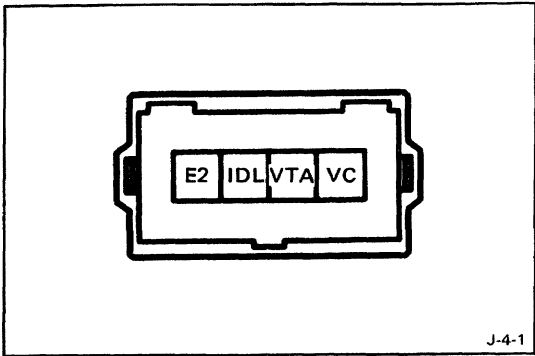

**5. INSPECT THROTTLE POSITION SENSOR**

Using an ohmmeter, check the resistance between each terminal.

Terminal	Throttle valve condition	Resistance (kΩ)
IDL - E <sub>2</sub>	Fully closed	2.3 kΩ or less
	Open	Infinity
VC - E <sub>2</sub>	-	4.25 - 8.25
VTA - E <sub>2</sub>	Fully closed	0.2 - 1.2
	Fully open	3.5 - 10.3

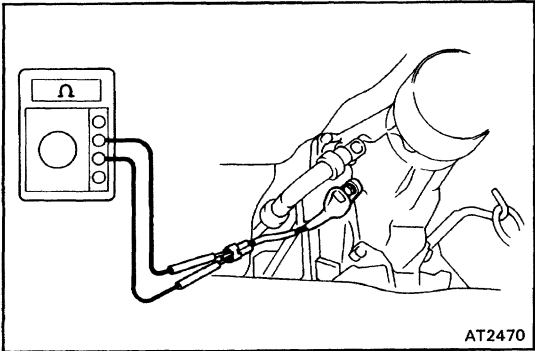

**6. INSPECT NO. 2 SPEED SENSOR**

(w/o ABS)

- (a) Jack up the rear wheel on one side.
- (b) Connect an ohmmeter between the connector and ground.
- (c) Spin the wheel and check that the meter needle deflects from 0Ω to ∞Ω.

(w/ABS)

(See page [BR-76](#))

**7. INSPECT NO. 1 SPEED SENSOR IN COMBINATION METER**

(See page [BE-39](#))

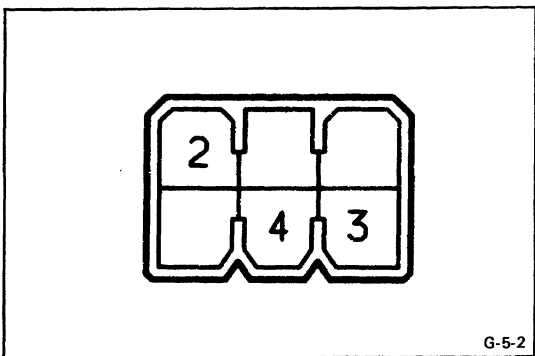

**8. INSPECT PATTERN SELECT SWITCH**

Inspect that there is continuity between 2 and each terminal.  
HINT: As there are diodes inside, be careful of the tester probe polarity.

Terminal	2	3	4
Pattern			
PWR	○	○	
NORM	○		○

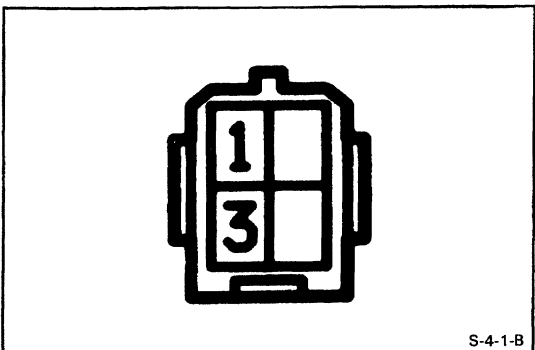

**9. INSPECT O/D SWITCH**

Inspect that there is continuity between terminals 1 and 3.

Terminal	1	3
S/W position		
ON		
OFF	○	○

**10. INSPECT WATER TEMPERATURE SENSOR**

(See page [FI-79](#))