

Diagnosis System DESCRIPTION

1. A self-diagnosis function is built into the electrical control system. Warning is indicated by the overdrive OFF indicator light.

HINT: Warning and diagnostic codes can be read only when the overdrive switch is ON. If OFF, the overdrive OFF light is lit continuously and will not blink.

(a) If a malfunction occurs within the speed sensors (No. 1 or 2) or solenoids (No. 1 or 2), the overdrive OFF light will blink to warn the driver.

However, there will be no warning of a malfunction with lock-up solenoid.

(b) The diagnostic code can be read by the number of blinks of the overdrive OFF indicator light when connect TDCL terminals, TE1 and E, or CHECK CONNECTOR terminals TE, and E1.

(c) The throttle position sensor or brake signal are not indicated, but inspection can be made by checking the voltage at TDCL terminal T_T .

(d) The signals to each gear can be checked by measuring the voltage at TDCL terminal T_T Of the service connector while driving.

2. The diagnostic code (trouble code) is retained in memory by the ECU (of Engine & ECT ECU) and due to back-up voltage, is not canceled out when the engine is turned off. Consequently, after repair, it is necessary to turn the ignition switch off and remove the EFI fuse (20A) or disconnect the TCCS ECU connector to cancel out the diagnostic (trouble) code. (See page AT-16)

HINT:

- Low battery voltage will cause faulty operation of the diagnosis system. Therefore, always check the battery first.
- Use a voltmeter and ohmmeter that have an impedance of at least 10 k Ω /V.

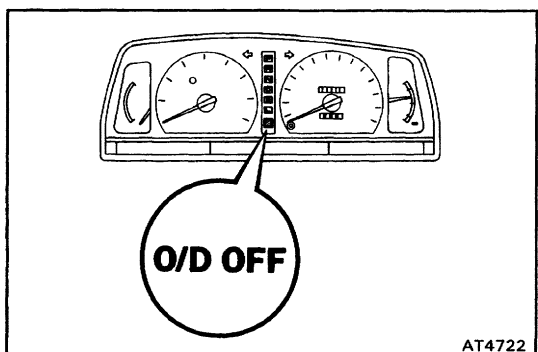

CHECK O/D OFF INDICATOR LIGHT

1. Turn the ignition switch ON.
2. The O/D OFF light will come on when the O/D switch is placed at OFF.
3. When the O/D switch is set to ON, the O/D OFF light should go out.

If the O/D OFF light flashes when the O/D switch is set to ON, the electronic control system is faulty.

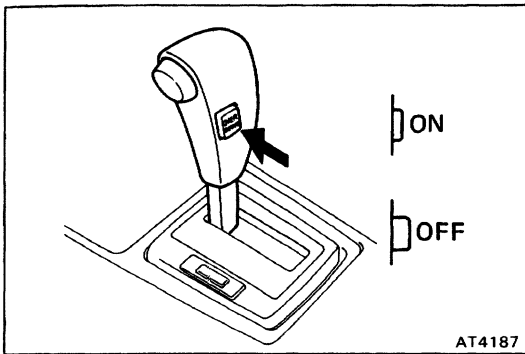

READ DIAGNOSTIC CODE

1. OUTPUT DIAGNOSTIC CODE

- (a) Turn on the ignition switch. Do not start the engine.
- (b) Turn on the O/D switch.

HINT: Warning and diagnostic codes can be read only when the overdrive switch is ON. If OFF, the overdrive OFF light will light continuously and will not blink.

- (c) Using SST, connect terminals.
 (with TDCL terminals T_{E1} , and E_1)
 SST 09843-18020

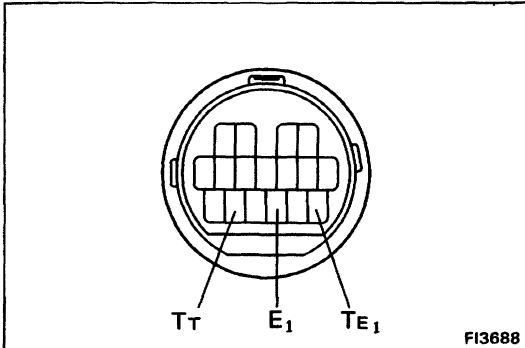

(with CHECK CONNECTOR terminals T_{E1} and E_1)

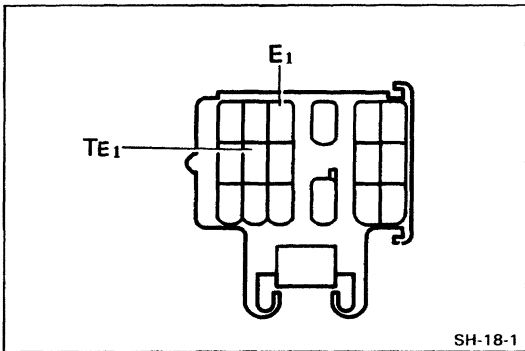

2. READ DIAGNOSTIC CODE

Read the diagnostic code as indicated by the number of times the O/D light flashes.

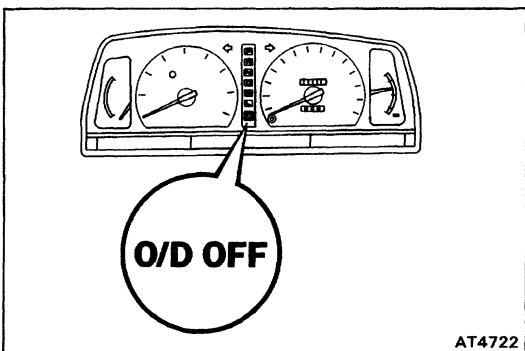

(Diagnostic Code Indication)

- If the system is operating normally, the light will blink 2 times per second.

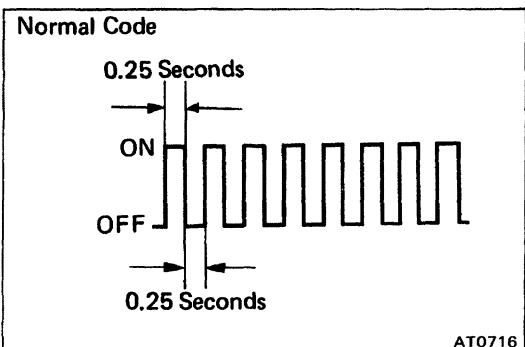

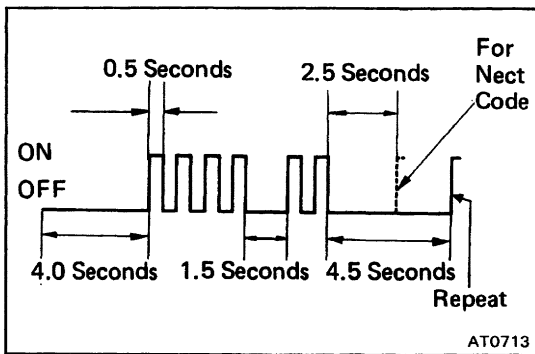

- In the event of a malfunction, the light will flash 1 time per second. The number of blinks will equal the first number and, after 1.5 seconds pause, the second number of the two digit diagnostic code. If there are two or more codes, there will be a 2.5 seconds pause between each.

HINT: In the event of several trouble codes occurring simultaneously, indication will begin from the smaller value and continue to the larger.

3. REMOVE SST

DIAGNOSTIC CODES

Code No.	Light Pattern	Diagnosis System
—		Normal
42		Defective No. 1 speed sensor (in combination meter) - severed wire harness or short circuit
61		Defective No. 2 speed sensor (in ATM) - severed wire harness or short circuit
62		Severed No. 1 solenoid or short circuit - severed wire harness or short circuit
63		Severed No. 2 solenoid or short circuit - severed wire harness or short circuit
64		Severed lock-up solenoid or short circuit - severed wire harness or short circuit

AT2020

HINT: If codes 62, 63 or 64 appear, there is an electrical malfunction in the solenoid. Causes due to mechanical failure, such as a stuck valve, will not appear.

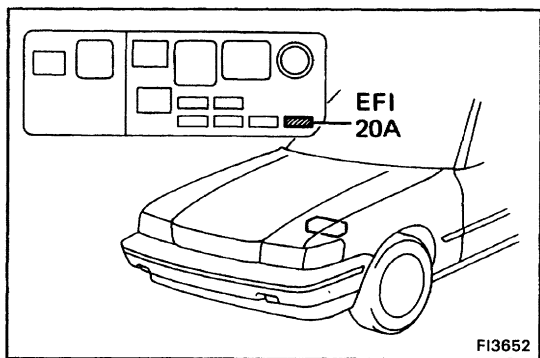

CANCEL OUT DIAGNOSTIC CODE

1. After repair of the trouble area, the diagnostic code retained in memory by the Engine & ECT ECU must be canceled by removing the EFI fuse (20A) for 10 seconds or more, depending on ambient temperature (the lower the temperature, the longer the fuse must be left out) with the ignition switch OFF.

HINT:

- Cancellation can be also done by removing the battery negative (-) terminal, but in this case other memory systems (ABS diagnosis memory, etc.) will be also canceled out.
- The diagnostic code can be also canceled out by disconnecting the Engine & ECT ECU connector.
- If the diagnostic code is not canceled out, it will be retained by the Engine & ECT ECU and appear along with a new code in event of future trouble.

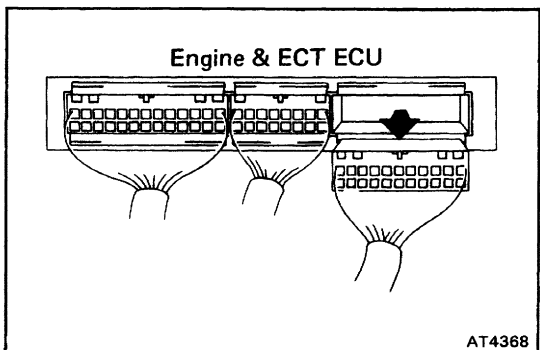

2. After cancellation, perform a road test to confirm that a "normal code" is now read on the O/D OFF light.

TROUBLESHOOTING FLOW-CHART

HINT:

- If diagnostic code Nos. 42, 61, 62 or 63 are output, the overdrive OFF indicator light will begin to blink immediately to warn the driver. However, an impact or shock may cause the blinking to stop; but the code will still be retained in the Engine & ECT ECU memory until canceled out.
- There is no warning for diagnostic code No. 64.
- In the event of a simultaneous malfunction of both No. 1 and No. 2 speed sensors, no diagnostic code will appear and the fail-safe system will not function. However, when driving in the D range, the transmission will not up-shift from first gear, regardless of the vehicle speed.

Diagnostic code 42 (No. 1 speed sensor circuitry)

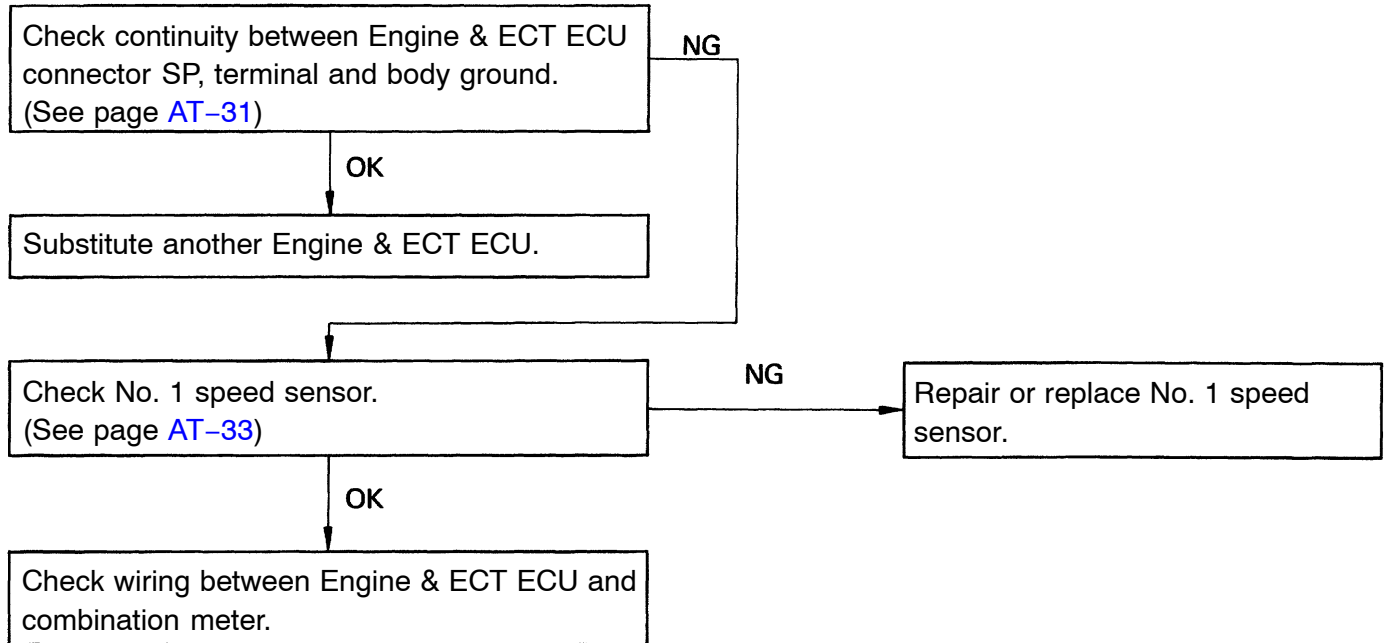

Diagnostic code 61 (No.2 speed sensor circuitry)

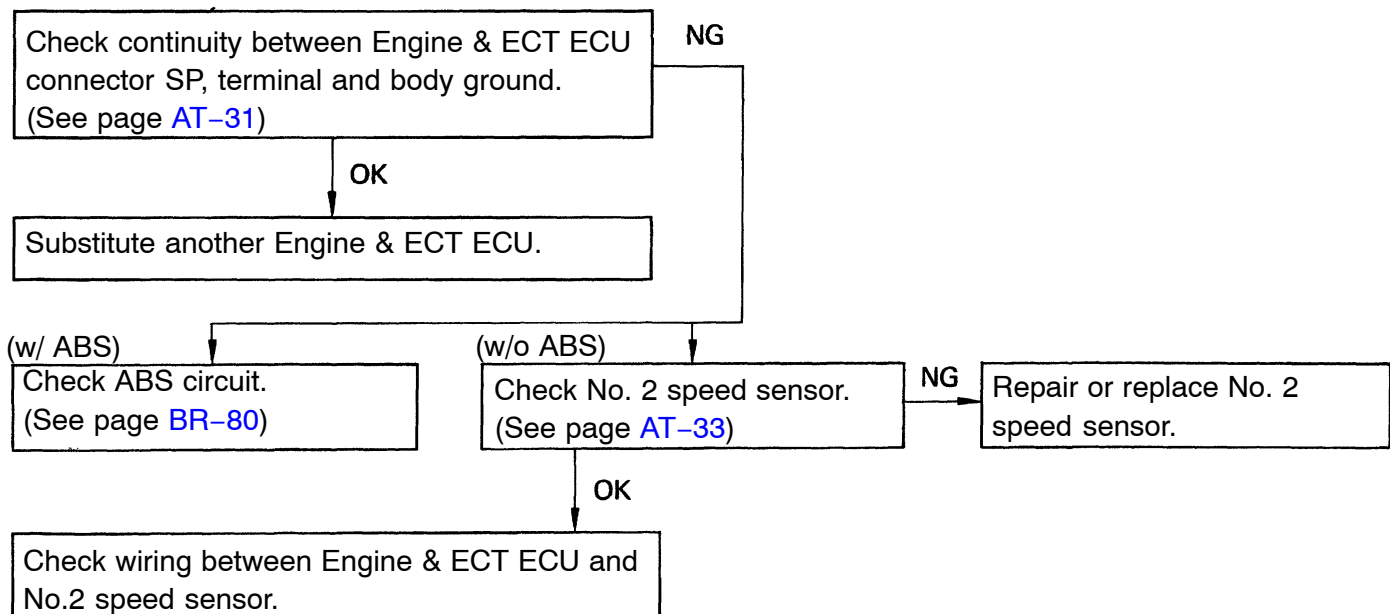

Diagnostic code 62 (No. 1 solenoid valve circuitry)

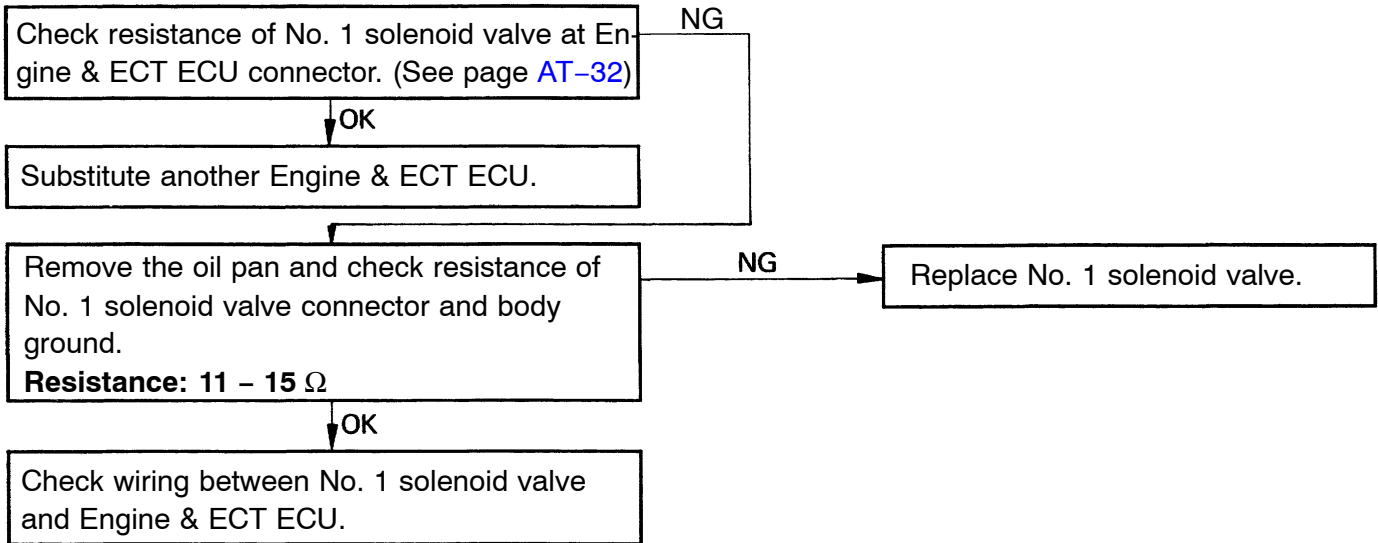

Diagnostic code 63 (No.2 solenoid valve circuitry)

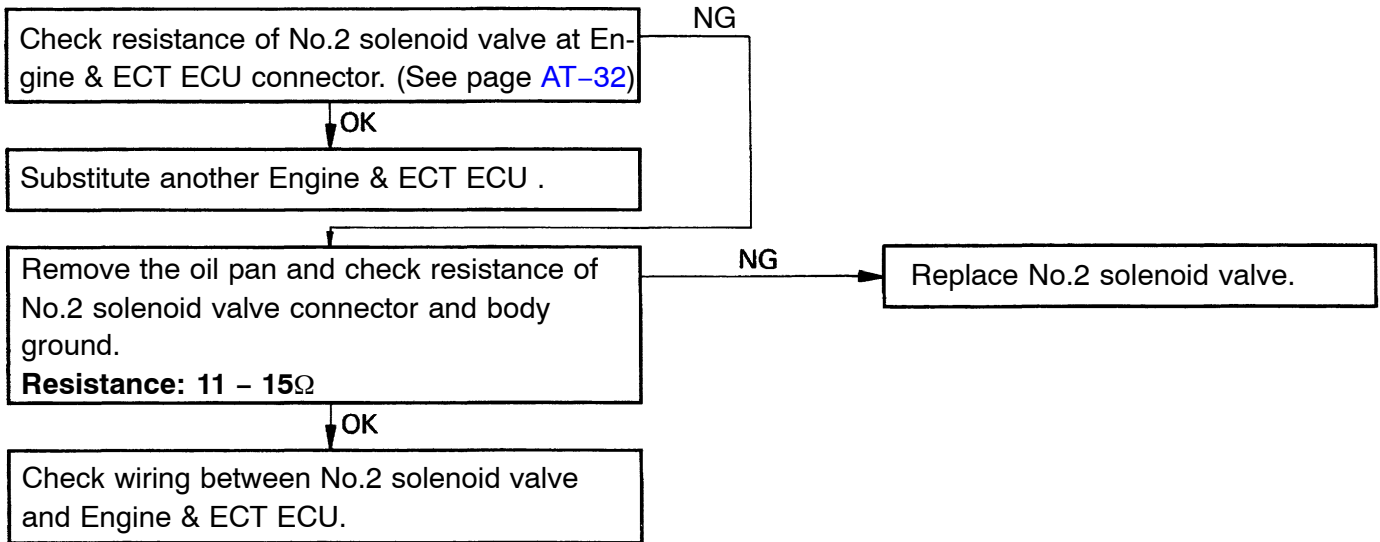

Diagnostic code 64 (Lock-up solenoid valve circuitry)

